

## Technical Bulletin

i-FR-G05-Z 2202 - 7223\_201811\_EN HFC R513A  
ELCA\_Engine ver.4.0.5.0



# i-FR-G05-Z 2202 - 7223

Chiller, air source for outdoor installation



(The photo of the unit is indicative and may vary depending on the model)

- LOW GWP REFRIGERANT
- HIGH EFFICIENCY
- ErP COMPLIANT 2021
- WIDE OPERATING RANGE
- REDUCED FOOTPRINT
- FLEXIBILITY
- ALUMINIUM MICRO-CHANNEL HEAT EXCHANGERS
- INTEGRATED HYDRONIC GROUP
- ADAPTABILITY
- HARMONY BETWEEN UNIT AND PLANT



## CERTIFICATIONS

---

### Product certifications



---

### Voluntary product certifications



Check ongoing validity of certificate:

[www.eurovent-certification.com](http://www.eurovent-certification.com)

or

[www.certiflash.com](http://www.certiflash.com)

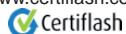

---

### System certifications



### **mitsubishi electric hydronics & it cooling systems s.p.a.**

Quality System complying with the requirements of UNI EN ISO 9001:2008 regulation  
Environmental Management System complying with the requirements of UNI EN ISO 14001:2004 regulation  
Occupational Health and Safety Management System complying with the requirements of BS OHSAS 18001:2007



1.1	PRODUCT PRESENTATION	pg.1.1.1 / 1.1.4
2.1	UNIT STANDARD COMPOSITION	pg.2.1.1 / 2.1.5
3.1	OPTIONS	pg.3.1.1 / 3.1.12
4.1	GENERAL TECHNICAL DATA	pg.4.1.1 / 4.1.12
5.1	OPERATING LIMITS	pg.5.1.1 / 5.1.5
6.1	HYDRAULIC DATA	pg.6.1.1 / 6.1.2
7.1	ELECTRICAL DATA	pg.7.1.1 / 7.1.5
8.1	FULL LOAD SOUND LEVEL	pg.8.1.1 / 8.1.6
9.1	DIMENSIONAL DRAWINGS	pg.9.1.1 / 9.1.4

**Liability disclaimer**

The present publication is drawn up by of information only and does not constitute an offer binding upon Mitsubishi Electric Hydronics & IT Cooling Systems S.p.A.

Mitsubishi Electric Hydronics & IT Cooling Systems S.p.A. has compiled the content of this publication to the best of its knowledge. The data contained herein are subject to change without notice. Mitsubishi Electric Hydronics & IT Cooling Systems S.p.A. explicitly rejects any liability for any direct or indirect damage, in the broadest sense, arising from or related to the use and/or interpretation of this publication. All content is copyrighted by Mitsubishi Electric Hydronics & IT Cooling Systems S.p.A.

The units highlighted in this publication contain R513A [GWP<sub>100</sub> 631] fluorinated greenhouse gases.



**Functions**

 COOLING Cooling

**Refrigerant**

 R513A R513A

**Compressors**

 SCREW Screw compressor

 INV.DRIVEN COMP. VSD Screw compressors

**Fan**

 AXIAL Axial fan

**Exchangers**

 SHELL & TUBES Shell & Tubes

**Other features right position**

 ENERGY CLASS Energy Class A

**Other features**

 EUROVENT CERTIFIED PERFORMANCE Eurovent  
www.eurovent-certification.com

 VPF VARIABLE PRIMARY FLOW VPF

 GREEN CERTIFICATION RELEVANT GREEN Certification relevant



## 1.1 PRODUCT PRESENTATION

### GREEN CERTIFICATION RELEVANT

Mitsubishi Electric Hydronics & IT Cooling Systems S.p.A., as a major player in the world HVAC market and a leading manufacturer of energy efficient, sustainable HVAC solutions, recognizes and supports the diffusion of green certification systems, as an effective way to deliver high performance buildings and improve the quality and the sustainability of the built environment.

Since the first certification system was introduced at the beginning of the 1990s, the demand for certified buildings has grown considerably, as well as the number of standards, rating and certification programs. Operating worldwide Mitsubishi Electric Hydronics & IT Cooling Systems S.p.A., has extensive experience with many of them and is active member of Green Building Council Italy.

Mitsubishi Electric Hydronics & IT Cooling Systems S.p.A., commitment to develop responsible and sustainable HVAC solutions, is reflected by a full range of premium efficiency products and systems, designed with special care to improve building energy performance ratings, according to major certification protocols, including LEED, BREAM, GREENSTAR, BCA, NABERS, DNGB, HQE and BEAM.

To find out more about how our products contribute to enhanced green certification rating and energy performance of a building, please refer to:

<https://www.melcohit.com/GLOBAL/Company/Green-Certifications/QR%20code/>



INCIPIT

# i - FR - G05 - Z / SL-K 7223

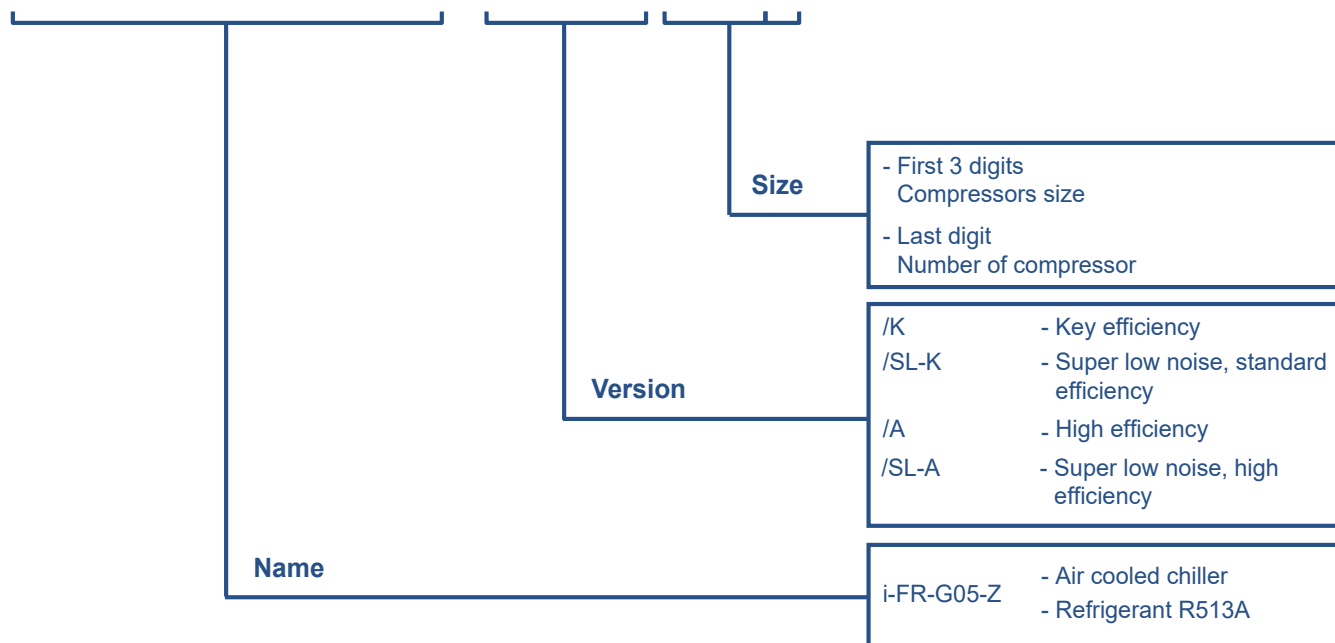

## PRODUCT PRESENTATION

Outdoor unit for the production of chilled water with semi-hermetic variable-speed screw compressors optimized for R513A, axial-flow fans, micro-channel full-aluminum condensing coils, single-pass shell and tubes evaporator designed by Mitsubishi Electric Hydraulics & IT Cooling Systems S.p.A. and electronic expansion valve.

Base and supporting structure and panels are of galvanized epoxy powder coated steel with increased thickness. Eurovent certification.

The screw compressors feature the variable speed technology thanks to the integrated refrigerant cooled inverter, for the maximum compactness and operating flexibility. Moreover, they feature the Variable Vi (compression ratio) technology, to change the internal geometry according to the operating conditions.

Thanks to the accurate sizing of all internal components and the use of variable speed technology, the unit ensures flexibility, reliability and maximum efficiency in every operating condition.

### 1.3 LOW GWP REFRIGERANT

New generation refrigerant R513A, with reduced greenhouse effect in comparison with traditional HFC refrigerants (Global Warming Potential GWP of R513A = 572, GWP of R134a = 1300 as per IPCC rev. 5th) and zero impact on the ozone layer. Not flammable (ASHRAE 34, ISO 817: class A1).

### 1.4 HIGH EFFICIENCY

Very high efficiency at full and partial load, at the highest market levels, thanks to the adopted technological solutions. These units ensure low operating costs and therefore a quick payback time.

### 1.5 ErP COMPLIANT 2021

Thanks to the inverter technology and the accurate design, the units already comply and exceed the minimum seasonal energy efficiency requirements that will start from 2021, imposed by the eco-sustainable design Directive 2009/125/EC.

### 1.6 WIDE OPERATING RANGE

The accurate condensation control (variable fan speed regulation as per standard on every model), the availability of devoted kits and smart control logics allow unit's operation from -20°C up to 55°C of outdoor air temperature and from -8°C to 20°C of evaporator leaving water temperature.

### 1.7 REDUCED FOOTPRINT

These new units have a reduced footprint, making them the best solution both for new plants (thanks to high efficiency) and for the replacement of obsolete units in existing plants, offering a very high efficiency increase with same dimensions and cooling capacity.

### 1.8 FLEXIBILITY

Flexibility in the applications thanks to the many configurations and versions available.

### 1.9 ALUMINIUM MICRO-CHANNEL HEAT EXCHANGERS

The full aluminium micro-channel condenser coils deliver high efficiency whilst ensuring a reduced refrigerant volume and a lower unit weight. The e-coating protection (optional) grants the highest level of resistance to corrosion in any condition, even in the most aggressive environments.

### 1.10 INTEGRATED HYDRONIC GROUP

The built-in hydronic group (optional) includes the main water circuit components. The 2 pumps are in twin configuration and available with 2 or 4-pole motor, fixed or variable speed, high or low head, to satisfy the different installation requirements.

### 1.11 ADAPTABILITY

Adaptability at the building's heating request thanks to the continuous capacity regulation, assured by sophisticated control's logic.

### 1.12 HARMONY BETWEEN UNIT AND PLANT

Low inrush current and power factor higher than similar fixed speed units, permit an easy electrical installation which is not stressed during start-up and with no need of extra devices for power factor correction. The use of VSD technology allows the unit to partialize in a stepless way, with consequent lower fluctuations of leaving water temperature.

## 2.1 UNIT STANDARD COMPOSITION

### CONFIGURATIONS

- , standard unit

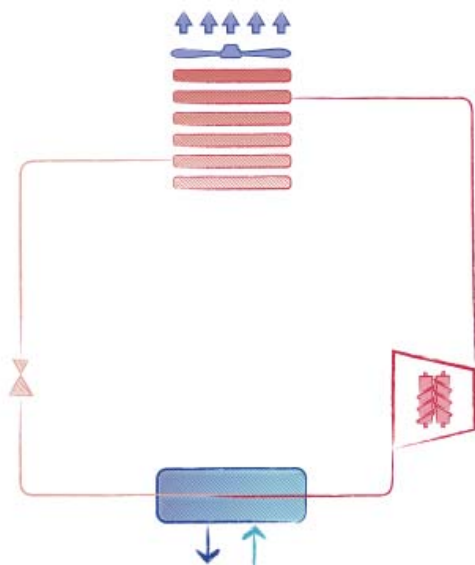

No heat recovery is possible.

### /D, unit with partial heat recovery

Heat recovery: ON

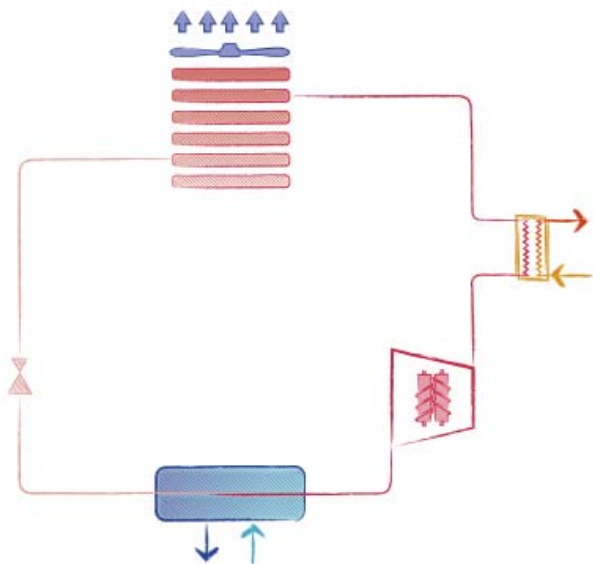

Heat recovery: OFF (water flow stopped)

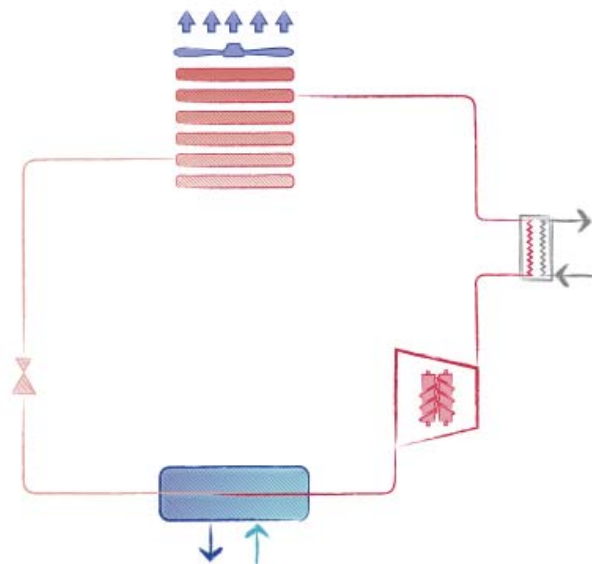

Each refrigerant circuit is fitted with a desuperheater.

The superheating heat recovery is only possible when the temperature of the hot water circuit is lower than the compressor discharge temperature. The heat recovery and its amount depends on the unit's operating conditions, in particular the outdoor air temperature and the load percentage. It is advised to interrupt the water flow to the desuperheater when the conditions for an actual heat recovery are not met.

The smart management of the desuperheater pump(s) is possible with the option 3371 D - RELAY 1 PUMP (ON/OFF), further information is available in the bulletin section dedicated to accessories.

## UNIT STANDARD COMPOSITION

Partial heat recovery operating limits:

	MIN temperature	MAX temperature
Inlet water	25°C (77°F)	56°C (132,8°F)
Outlet water	30°C (86°F)	60°C (140°F)

### /R, unit with total heat recovery

Heat recovery: ON

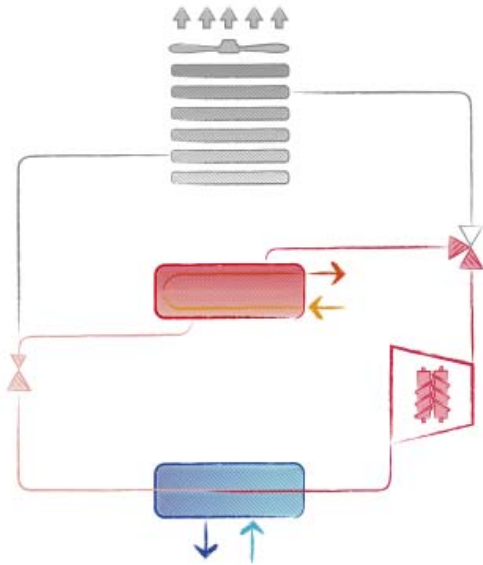

Heat recovery: OFF

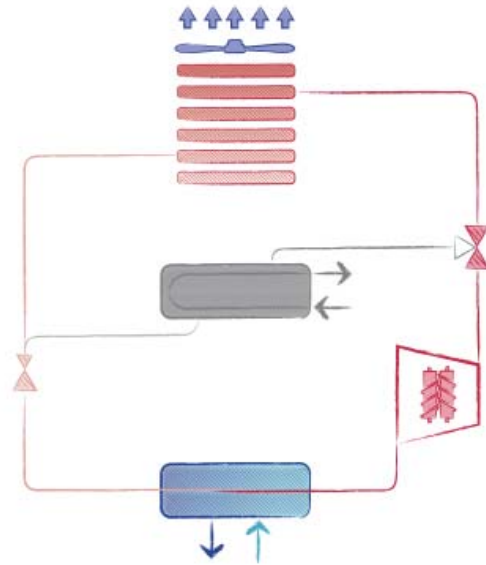

Each refrigerant circuit is fitted with a total heat recovery exchanger.

The heat recovery mode is managed according to the hot water temperature set-point.

When the heat recovery mode is active, the condensation takes place in the devoted refrigerant/water heat exchanger instead of in the finned coils.

The available hydronic modules and primary flow control options for the total heat recovery exchanger are listed in the bulletin section dedicated to accessories.

Total heat recovery operating limits:

	MIN temperature	MAX temperature
Inlet water	18°C (64,4°F)	56°C (132,8°F)
Outlet water	26°C (78,8°F)	60°C (140°F)

## UNIT STANDARD COMPOSITION

### 2.2 Chiller, air source for outdoor installation

Outdoor unit for the production of chilled water with semi-hermetic variable-speed screw compressors optimized for R513A, axial-flow fans, micro-channel full-aluminum condensing coils, single-pass shell and tubes evaporator designed by Mitsubishi Electric Hydraulics & IT Cooling Systems S.p.A. and electronic expansion valve.

Base and supporting structure and panels are of galvanized epoxy powder coated steel with increased thickness. Eurovent certification.

The screw compressors feature the variable speed technology thanks to the integrated refrigerant cooled inverter, for the maximum compactness and operating flexibility. Moreover, they feature the Variable Vi (compression ratio) technology, to change the internal geometry according to the operating conditions.

Thanks to the accurate sizing of all internal components and the use of variable speed technology, the unit ensures flexibility, reliability and maximum efficiency in every operating condition.

### 2.3 Installation note

The unit is supplied fully refrigerant charged and factory tested. On site installation only requires power and hydraulic connection.

### 2.4 Structure

Structure specifically designed for outdoor installation. Base and frame in hot-galvanized steel sheet of suitable thickness. All parts polyester-powder painted to assure total weather resistance. Painting: RAL 7035 textured finish.

### 2.5 Refrigerant circuit

Unit designed with separate and independent refrigerant circuits in order to ensure continuous operation and easy maintenance. In addition to the main components described in the following sections, each refrigerant circuit is fitted as standard with:

- electronic expansion valve
- high and low pressure transducers
- visualization of the pressure's level directly from the controller's interface
- safety switching device for limiting the pressure
- high and low pressure safety valve
- liquid line shut-off device (function performed by electronic expansion valve with ultracap)
- non -return valve in compressor's discharge line integrated in the compressor
- compressor's discharge valve
- liquid line shut-off valve
- refrigerant line sight glass with humidity indicator
- drier filter with replaceable cartridge
- economizers on the following models:  
3902 (all versions); 4202 (all versions); 4502 (all versions); 6303 (all versions); 6903 (K, SL-K); 5703 (A, SL-A); 6603 (A, SL-A).

### 2.6 Inverter-screw compressors

CSCV screw-compressors designed according to Mitsubishi Electric Hydraulics & IT Cooling Systems S.p.A. specifications and for its exclusive use.

Extremely compact compressors, with oil separator, frequency modulation inverter and inverter cooling system integrated in a single casing.

Semi-hermetic screw-compressors with 2 five and six-lobe rotors: the five-lobe rotor is directly splined onto the motor, without the use of overgears. The motor activates the male screw at a speed varying from 1 to 6 thanks to the coupling with the dedicated inverter.

The cooling of the inverter is performed by an integrated plate: a coolant passes through and its flow is controlled by special valves. Only a connection with the refrigerant liquid line is necessary. The presence of additional heat exchangers is not required.

The bearings placed on the axle of the rotors in a special chamber, separated from the compression chamber, are made of carbon steel to obtain maximum strength and ensure long lifetime (> 150.000 h) at any speed. Lubrication: the oil is distributed to the mechanic components without using an oil pump so that compression is optimised. The oil separator is incorporated to achieve maximum compactness. It performs a three-stage separation using a 10 micron steel mesh filter that ensures the constant presence of oil in the compressor.

Innovative mechanic design with inner slider, managed according to specific proprietary parameters, for the variation of Vi depending on the different operating conditions. This allows to achieve maximum efficiency even in case of considerable load partialization.

High reliability ensured by the continuous control of the operating parameters and by automatic functions that bring the compressor back into the envelope in case the unit gets too close to operating limit values. Each compressor is fitted with manual-reset motor thermal protection, delivery gas temperature control, oil level and an electric heater for

heating the oil when the compressor is stopped.

The inverter power circuit is equipped with a line reactor used to control the emissions of the power line and ensure conformity to standard EN 61000-6-4 for industrial environments.

Check valve fitted on the refrigerant delivery line to prevent the rotor from reversing after stopping. Shut off valve fitted on the delivery line of each compressor in order to confine the coolant charge in the exchangers, if required.

Liquid injection circuit.

Compressor soft-start function with steady current increase without peaks.

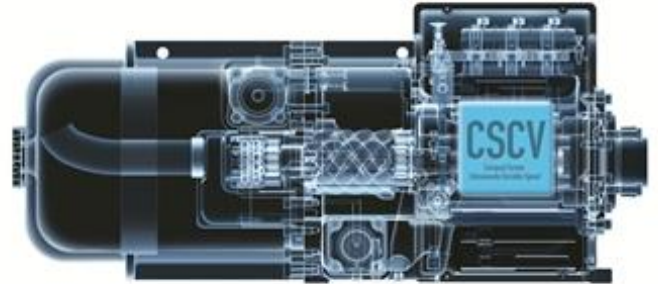

- The minimum percentage of cooling capacity of the unit (referred to the conditions of water produced at 7 ° C, air 35 ° C) is:  
13% for 2-compressor units  
8% for 3-compressor units

### 2.7 Plant side heat exchanger

Dry expansion type shell and tube heat exchanger; it acts as an evaporator with refrigerant flow inside the pipes and water flow on the shell side. Fully developed and manufactured by Mitsubishi Electric Hydraulics & IT Cooling Systems S.p.A., the heat exchanger is a single pass type to provide almost perfect countercurrent heat exchange. The water flow on the shell side is fitted with baffles to increase turbulence and therefore the efficiency of exchange. The steel shell has insulation lining made of flexible closed cells elastomeric foam (thermal conductivity 0.033W/mK at 0°C) coupled with 3 mm layer of crosslinked PE foam with a surface film of embossed PE for a total thickness of 9 mm. The tube nest is manufactured using copper tubes with internal grooves to improve heat exchange and each pipe is mechanically expanded onto the tube plates. The heat exchanger is fitted with a differential pressure switch which controls the flow of water when the unit is working, in this way preventing the formation of ice inside; when pumps stop, the antifreeze control is up to an electrical resistance. The heat exchanger is made in compliance with PED standard work pressure requisites. Upon request, the heat exchanger can be supplied AS1210 compliant or with the SafeWork NSW certificate, depending on the size. For some sizes (versions K, SL-K: 5412, 6002, 6022; versions A, SL-A: 4822, 5412), the AS1210 heat exchanger has another trademark.

- User-side heat exchanger connections H type accessible with grooved coupling with weld end counter-pipe user side (supplied separately). The connections are on the left side of the machine looking at the electrical panel of the unit.

### 2.8 Source side heat exchanger

Microchannel coils ideally positioned on a "V" block structure to optimize airflow and heat transfer. Made entirely in aluminum, the coils are not subjected to galvanic corrosion.

Fins and manifolds are made of aluminum AA3003 while the channels are made of a new aluminum alloy so defined Long Life Alloy (LLA). LLA alloy has a very fine grain microstructure that guarantees higher mechanical properties and a higher resistance to the inter-granular corrosion.

Channel small section favor refrigerant fluid turbulence, which enhances the heat exchange. Tube geometry maximize the surface touched by the air, thus allowing compact dimension and refrigerant charge reduction.

### 2.9 Fan section source side

K, SL-K versions: Axial electric fans, protected to IP 54 and with insulation class 'F', featuring an external rotor and profiled blades. Housed in an aerodynamic hood complete with safety guard. The fan + outlet set satisfies the efficiency requirements provided for by EcoDesign directive 327/11.

6-pole electric motor with built-in thermal protection. Variable Speed Device (DVVF) for controlling condensation by adjusting the speed of rotation with voltage steps (auto-transformer), fitted with a ventilation



## UNIT STANDARD COMPOSITION

distribution system in case of external air low temperature. In conformity with the adjustment logic, each condenser circuit has a totally independent ventilation system.

A, SL-A, K+EC fans (opt. 808), SL-K+EC fans (opt. 808) versions: Axial electronically commutated fans (EC fans), with external rotor, profiled die-cast aluminium blades, housed in aerodynamic hoods complete with guard grille. 6-poles electric motor with built-in thermal protection. The brushless motor, governed by a special controller, continuously adjust fans' speed to minimize energy consumption, electromagnetic noises and current's absorption even during start-up phase. The fans are fitted with a ventilation distribution system to allow the operation with low external air temperature.

### 2.10 Super Low noise version features

The Super Low noise units (SL-K, SL-A versions) feature:

- Condensing section larger than the corresponding standard version's one
- Special soundproofing insulation of the compressors enclosure (multilayer lining of polyurethane foam and double sound-insulating gaiter, total thickness 52 mm)
- Soundproofing lining of suction and delivery pipes of the compressors with 9mm anti-condensation mat, 1mm insulating viscous coating and 8mm cross-linked polyethylene foam coating.
- Reduced fan speed (the speed is automatically increased in case of particularly tough environmental conditions).
- Covering of the exposed pipes between the V-blocks with painted metal sheets with a special soundproofing insulation (multilayer lining of polyurethane foam and sound-insulating gaiter, total thickness 30 mm)
- If the hydronic is present, the pump enclosure is acoustically insulated by a 30 mm thick lining of polyester fibres (Fiberform)

### 2.11 Electrical and control panel

Electrical and control panel built to EN60204-1 and EC204-1 standards, complete with:

- general door lock isolator
- control circuit transformer
- IP44 XW protection
- power circuit with electric bus bar distribution system
- spring-type control circuit terminal board
- forced ventilation of the electrical board
- phases sequence control
- sectionable extra-rapid fuses to protect compressors
- numbered cables
- Pump control relay + 0-10V modulating signal to control an external variable speed pump with the parameter-set constant water flow control logic
- relays for voltage monitoring
- compressors protection with internal thermal overload
- electronic controller
- remote ON/OFF terminals
- terminals for cumulative alarm block
- kit on the power circuits of the compressors for conducted emissions on the power line compliant with EN61000-6-4 for industrial environments
- Power supply 400V/3ph/50Hz

### 2.12 Certification and applicable directives

The unit complies with the following directives and relative amendments:

- EUROVENT Certification program
- CE Declaration of conformity certificate for the European Union
- EAC Product quality certificate for Russian Federation
- M&I Product quality certificate for Australia and New Zealand
- Machine directive 2006/42/EC
- PED Directive 2014/68/EC
- Low Voltage directive 2006/95/EC
- ElectroMagnetic compatibility directive 2004/108/EC
- ErP Directive 2009/125/EC
- ISO 9001 Company's Quality Management System certification
- ISO 14001 Company's Environmental Management System certification

### 2.13 Tests

Tests performed throughout the production process, as indicated in ISO9001.

Performance or noise tests can be performed by highly qualified staff in the presence of customers.

Performance tests comprise the measurement of:

- electrical data
- water flow rates
- working temperatures
- power input
- power output

- pressure drops on the water-side exchanger both at full load (at the conditions of selection and at the most critical conditions for the condenser) and at part load conditions.

During performance testing it is also possible to simulate the main alarm states.

Noise tests are performed to check noise emissions according to ISO9614.

### 2.14 Electronic control W3000 TE

The W3000TE controller offers advanced functions and algorithms.

KIPLink - Keyboard In Your Pocket - is the innovative user interface based on WiFi technology that allows one to operate on the unit directly from the smartphone or tablet. Using KIPLink, it is possible to turn the unit on and off, adjust the set-point, plot the main operating variables, monitor in detail the status of the refrigerant circuits, the compressors, the fans and the pumps (if present) and display and reset the possible alarms. In addition to or as an alternative, the Touch interface, with a 7" WVGA colour display and a front USB port, or the Large keyboard, with a wide LCD display and led icons, are available. The temperature control is characterized by the continuous capacity modulation, based on PID algorithms with dynamic neutral zone related to the leaving water temperature. The diagnostics comprises a complete alarm management system, with the "black-box" (via PC) and the alarm history display (via user interface or also PC) for enhanced analysis of the unit operation.

Optional proprietary devices can perform the adjustment of the resources in systems made of several units. Consumption metering and performance measurement are possible as well. Supervision can be easily developed via proprietary devices or the integration in third party systems by means of the most common protocols as ModBus, Bacnet, Bacnet-over-IP, LonWorks. Compatibility with the remote keyboard (up to 8 units). The programmable timer manages a weekly schedule organized into time bands to optimise unit performance by minimising power consumption during periods of inactivity. Up to 10 daily time bands can be associated with different operating set points. As an option (VPF package), the modulation of capacity is integrated with the modulation of the water flow, by means of inverter and dedicated resources for the hydraulic circuit.



### 2.15 Versions

#### /K - Key efficiency

Key efficiency units that grant the best cooling capacity/footprint ratio.

#### /A - High efficiency

High efficiency unit, both at full and part load, which minimizes the investment payback time thanks to high performing heat exchangers, generous heat exchanger's surfaces and EC brushless fans.

#### /SL-K - Super low noise, standard efficiency

## UNIT STANDARD COMPOSITION

Key efficiency units that grant the best cooling capacity/footprint ratio.

This version features a special soundproofing for the compressor compartment and the pumps (if present), a reduced fan speed and an oversized condensing section.

The fan speed is automatically increased in case of particularly tough environmental conditions.

### **/SL-A - Super low noise, high efficiency**

High efficiency units for the minimum investment payback time. High performing heat exchangers, generous heat exchanger's surfaces and EC brushless fans.

This version features a special soundproofing for the compressor compartment and the pumps (if present), a reduced fan speed and an oversized condensing section.

The fan speed is automatically increased in case of particularly tough environmental conditions.

## **2.16 Configurations**

### **- , standard unit**

Standard unit for production of chilled water

### **/D, unit with partial heat recovery**

Unit for the production of chilled water, equipped with an auxiliary heat exchanger (desuperheater) on the compressor discharge for superheat recovery. The recovered heat is approximately the 20% of the total cooling capacity and can be used for domestic hot water production or other secondary uses, such as the integration of an existing boiler.

### **/R, unit with total heat recovery**

Unit for the production of chilled water, with a dedicated heat exchanger refrigerant/water for the condensation heat reclaim. The heat reclaim is managed to reach the set-point. This function is used for air treatment in applications with AHU or for domestic hot water production together with an auxiliary boiler.



### 3.1 OPTIONS

OPTIONS	DESCRIPTIONS	BENEFITS	AVAILABLE FOR MODELS
<b>1560 POWER SUPPLY CONFIGURATION</b>			
1561 DOUBLE POWER SUPPLY (ATS)	An ATS (Automatic Transfer Switch) is installed within the electrical board. The device automatically switches the electrical load between a principal power supply (i.e. mains) and an auxiliary power supply (i.e. backup generator). The ATS automatically senses if one of the sources has lost or gained power. When an outage occurs in the principal power supply, the switch autonomously switches over to the secondary line. When the main line becomes available again the supply is restored to this line. It is possible to set the line priority and frequency of checking.	It enhances system's redundancy and reliability. Reduces unit's downtime in case of mains power outage.	ALL
1562 DOUBLE P.SUPPLY (MOTOR. CH.OVER)	A motorized changeover is installed within the electrical board. The device switches the electrical load between a principal power supply (i.e. mains) and an auxiliary power supply (i.e. backup generator). The changeover is with remote control (i.e. signal of generator start up).	It enhances system's redundancy and reliability. Reduces unit's downtime in case of mains power outage.	ALL
<b>1020 REGULATIONS</b>			
1015 HEAT EXCHANGERS NSW CERTIFIED	Heat exchangers with SafeWork NSW certificate		ALL
1017 UNIT PED-UDT COMPLIANT	Unit PED-UDT compliant for Polish market		ALL
1019 HEAT EXCHANGERS AS1210 CERTIFIED	Heat exchangers AS1210 compliant (Australia Standard)		ALL
<b>380 NUMBERED WIRING</b>			
381 NUMBERED WIRING ON EL. BOARD	Electrical board wires are identified by numbered labels. The reference numbers are indicated in the unit's wiring scheme.	Facilitate maintenance interventions to the electrical board connections.	ALL
383 NUMBERED WIRINGS+UK REQUESTS	Electrical board wires are identified by numbered labels. The reference numbers are indicated in the unit's wiring scheme.	Facilitate maintenance interventions to the electrical board connections.	ALL
<b>3410 AUTOMATIC CIRCUIT BREAKERS</b>			
3414 AUTOM. CIRCUIT BREAK. ON LOADS (COMPR. EXCL.)	Over-current switch on the major electrical loads, compressors excluded.	In case of overcurrent allows resetting of the switch without the replacement of relative fuses.	ALL
<b>3600 ON/OFF COMPRESSOR SIGNAL</b>			
3601 COMPRESSOR OPERATION SIGNAL	Auxiliary contacts providing a voltage-free signal.	Allows remote signalling of compressor's activation or remote control of any auxiliary loads.	ALL
<b>4180 REMOTE CONNECTION ARRANGEMENT</b>			
4181 SERIAL CARD MODBUS	Interface module for ModBUS protocols.	Allows integration with BMS operating with ModBUS protocol.	ALL
4182 SERIAL CARD FOR LONWORKS	Interface module for Echelon systems.	Allows integration with BMS operating with LonWorks protocols	ALL
4184 SERIAL CARD BACNET MS/TP RS485	Interface module for BACnet protocols.	Allows integration with BMS operating with BACnet protocol.	ALL

**OPTIONS**

OPTIONS	DESCRIPTIONS	BENEFITS	AVAILABLE FOR MODELS
4185 SERIAL CARD FOR BACNET OVER IP	Interface module for BACnet OVER-IP protocols.	Allows to interconnect BACnet devices over Internet Protocol within wide-area networks.	ALL
4187 M-Net W3000 INTERFACE KIT	Interface kit for M-Net protocol.	Interface module to allow the integration of the unit with Mitsubishi Electric proprietary communication protocol M-Net.	ALL
<b>6160 AUXILIARY INPUT</b>			
6161 AUXILIARY SIGNAL 4-20mA	4-20 mA analog input	Allows to change the operating set-point according to the value of current applied to the analogue input.	ALL
6162 REMOTE SIGNAL DOUBLE SP	Allows to activate the Energy Saving set-point.	Allows to change the operating set-point according to a remote switch	ALL
<b>6170 DEMAND LIMIT</b>			
6171 INPUT REMOTE DEMAND LIMIT	Digital input (voltage free)	It permits to limit the unit's power absorption for safety reasons or in temporary situation.	ALL
<b>1440 USER INTERFACE</b>			
1442 KIPlink +7 INCH TOUCH SCREEN	In addition to KIPlink, the innovative user interface based on WiFi technology, the unit is equipped with the Touch interface, with a 7" WVGA colour display and a front USB port (WARNING: with outdoor temperature below 0°C the display response time may visibly increase).		ALL
1444 KIPlink + LARGE KEYBOARD	In addition to KIPlink, the innovative user interface based on WiFi technology, the unit is equipped with the Large keyboard with a wide LCD display and led icons.		ALL
6194 LARGE KEYBOARD	The unit is equipped with the Large keyboard with a wide LCD display and led icons.		ALL
6195 7 INCH TOUCH SCREEN	The unit is equipped with the Touch interface, with a 7" WVGA colour display and a front USB port (WARNING: with outdoor temperature below 0°C the display response time may visibly increase).	The touch-screen's technology is characterized by an easy-to-access data, and it allows an effective graphical representation of the main figures protecting the access through 3 privilege levels.	ALL
6196 KIPlink	The unit is equipped with KIPlink, the innovative user interface based on WiFi technology		ALL
<b>3420 LIGHTS ON ELECTRIC BOARD</b>			
3421 LIGHTS ON ELECTRIC BOARD	Electrical board equipped with lights.	Facilitate electrical board maintenance interventions.	ALL
<b>3390 ANTICONDENSATE HEATER EL.BOARD</b>			
3391 ELECTRIC HEATER ON EL. BOARD	Electrical heater fed directly from the unit, is automatically activated at temperatures internal QE below 30 ° C (off state at T higher than 40 ° C).	It avoids the risk of humidity condensation on the electrical panel.	ALL
<b>5920 MANAGEMENT &amp; CONTROL SYSTEMS</b>			
5921 NETWORK ANALYZER FOR DEMETRA	This option includes all following devices on-board the unit panel: - network analyzer operating on ModBUS protocol over RS-485 (without certification MID) - current transformers.	This accessory allows to acquire the electrical data and the power absorbed by the unit and send them via RS-485 bus to an external device for energy metering (DEMETRA - see dedicated manual).	ALL

## OPTIONS

OPTIONS	DESCRIPTIONS	BENEFITS	AVAILABLE FOR MODELS
5922 ClimaPRO ModBUS RS485 - MID	This option includes all following devices on-board the unit panel: - MID certified network analyzer operating on ModBUS over RS-485 - Current transformers - W3000TE controller - Software release LA09 or later version.	This accessory allows to acquire the electrical data and the power absorbed by the unit and communicate with ClimaPRO via high level communication interface based on ModBUS over EIA RS-485. More specifically, the data collected are: power supply, current, frequency, power factor ( $\cos\phi$ ), electrical power consumption, energy consumption. This specific energy meter model is MID certified and can therefore be used for billing applications. This option also ensures the compatibility between the units and ClimaPRO, thus allowing ClimaPRO to acquire all the main unit's operating variables and status by means of a high level communication interface to the controller installed onboard the unit panel.	ALL
5923 ClimaPRO BacNET over IP	This option includes all following devices on-board the unit panel: - network analyzer operating on BACnet over IP - Current transformers - W3000TE controller - Software release LA09 or later version.	This accessory allows to acquire the electrical data and the power absorbed by the unit and communicate with ClimaPRO via high level communication interface based on BACnet over IP. More specifically, the data collected are: power supply, current, frequency, power factor ( $\cos\phi$ ), electrical power consumption, energy consumption. This network analyzer is not MID certified and cannot therefore be used for billing applications. This option also ensures the compatibility between the units and ClimaPRO, thus allowing ClimaPRO to acquire all the main unit's operating variables and status by means of a high level communication interface to the controller installed onboard the unit panel.	ALL
5924 ENERGY METER FOR BMS	This option includes all following devices on-board the unit panel: - network analyzer with display operating on ModBUS protocol over RS-485 (without certification MID) - current transformers.	This accessory allows to acquire the electrical data and the power absorbed by the unit and send them via RS-485 bus to the BMS for energy metering.	ALL
<b>4500 FAST RESTART (UPS EXCLUDED)</b>			
4501 FAST RESTART (UPS EXCLUDED)	Unit fast restart management after power failure	The management of the fast restart allows to minimize downtimes in case of power failure, keeping all the necessary unit safeties. This option requires an external 203V AC 300VA UPS power supply, by customer.	ALL
4502 FAST RESTART (UPS INCLUDED)	Unit fast restart management after power failure	The management of the fast restart allows to minimize downtimes in case of power failure, keeping all the necessary unit safeties. This option includes an electric device capable of keeping the controller power supply uninterrupted during a power failure. For duration of the UPS longer than 30 minutes, please contact our sales department.	ALL
<b>1570 POWER SOCKET</b>			
1571 POWER SOCKET 230V MAX 500VA	230V power socket in the electrical board, CEE 7/3 type (Schuko). The maximum power available is 500VA.	It allows to supply power to small electric/electronic devices (lights, notebook, tablet, etc.) during maintenance operation.	ALL

## OPTIONS

OPTIONS	DESCRIPTIONS	BENEFITS	AVAILABLE FOR MODELS
<b>3430 REFRIGERANT LEAK DETECTOR</b>			
3431 REFRIG. LEAK DETECTOR	Refrigerant leak detection system, supplied factory mounted and wired in the electrical board. In case of leak detection it will raise an alarm.	It promptly detects gas leakages	ALL
3433 GAS LEAK CONTACT + COMPR. OFF	Refrigerant leak detection system, supplied factory mounted and wired in the electrical board. In case of leak detection it will raise an alarm and stop the unit.	It promptly detects gas leakages and stops the unit	ALL
<b>820 FAN CONTROL</b>			
808 EC FANS	Electronically commutated fans (EC fans). The brushless motor, governed by a special controller, continuously adjust fans' speed.	Reduced energy consumption and minimized current's absorption during start-up phase. The efficiency is increased by approximately: +1% of EER and +4/5% of ESEER. The noise reduces proportionally to the unit's partialization.	ALL
<b>1950 HIGH TEMPERATURE DEVICE</b>			
1955 KIT HT	Kit to increase the unit's operating range.	Full load operation is guaranteed up to over 50°C of outdoor temperature (the limit depends on the unit version, further details are available in the operating limit section). In case of outdoor air temperature higher than 53°C, some additional cooling equipment for the electrical panel could be necessary (please refer to our sales department for assessment and quotation).	ALL
<b>1960 PRESSURE RELIEF VALVES</b>			
1961 DUAL RELIEF VALVES WITH SWITCH	Dual relief valve with switch	Allows to unselect a relief valve in order to service the unit avoiding medium or long inoperative periods	ALL
<b>1400 HP AND LP GAUGES</b>			
1401 HP AND LP GAUGES	High and low pressure gauges	Allows immediate reading of the pressure values on both low and high pressure circuits	ALL
<b>1900 COMPRESSOR SUCTION VALVE</b>			
1901 COMPRESSOR SUCTION VALVE	Shut-off valve on compressor's suction circuit.	Simplifies maintenance activities	ALL
<b>870 OPERATION RANGE UNIT</b>			
871 NEGATIVE FLUID TEMPERATURE	Compressor's liquid injection	It permits the compressor works properly with high compression efficiency with negative evaporator leaving temperature	ALL
<b>2630 INSULATION ON EXCHANGERS</b>			
2631 DOUBLE INSULATION ON EXCHANGERS	Thermal insulation in closed-cell flexible elastomeric foam (FEF) of 16 mm coupled with a 3 mm layer of reticulated foam in PE and an exterior embossed finishing PE film. This option is mandatory if the unit is supposed to work with outdoor temperature below -10°C.	Reduces heat losses and prevent from condensate problems.	ALL
<b>1800 EVAPORATOR WATER FLOW SWITCH</b>			
1801 EVAPORATOR WATER FLOW SWITCH	Flow switch with stainless scoop AISI 316L and IP65 protection suitable for installation in industrial plant pipes. It should be installed in a straight pipe without filters, valves, etc., long at least 5 times its diameter, both upstream and downstream.	Signaling of lack of or excessive reduction of flow, it generates an alarm that is in automatic or manual reset depending on n ° alarms per hour and the maximum time of operation of the pump under conditions of low flow rate.	ALL

**OPTIONS**

OPTIONS	DESCRIPTIONS	BENEFITS	AVAILABLE FOR MODELS
<b>990 CONDENSING COIL</b>			
876 E-COATING MICROCHANNEL COILS	The heat exchanger is completely treated by electrolysis so as to create a protective layer of epoxy polymer on the surface, with the following characteristics: - over 3120 hours of salt spray protection as per ASTM G85-02 A3 (SWAAT); - polyurethane surface protection against UV rays.	Provide a very high resistance against corrosion, also in very aggressive environment. For further information please refer to the Guidelines "Finned coil heat exchangers and protection against corrosion", available in the download section of the website <a href="http://www.climaveneta.com">www.climaveneta.com</a> , or contact our sales department.	ALL
879 COPPER/ALUMINIUM COILS	Finned coil heat exchanger made from suitably-spaced copper tubes and aluminum fins designed to ensure maximum heat exchange efficiency.	Provide a good resistance against corrosion. For further information please refer to the Guidelines "Finned coil heat exchangers and protection against corrosion", available in the download section of the website <a href="http://www.climaveneta.com">www.climaveneta.com</a> , or contact our sales department.	i-FX-G05 /A: 2202, 2602, 2652, 2702, 2722, 3152, 3602, 3902, 4202, 4502, 4802, 4822, 5412, 5703, 6303, 6603. i-FX-G05 /K: 2202, 2602, 2652, 2702, 2722, 3152, 3602, 3902, 4202, 4502, 4802, 4812, 4822, 5412, 6002, 6022, 6303, 6903, 7203, 7213, 7223. i-FX-G05 /SL-A: 2202, 2602, 2652, 2702, 2722, 3152, 3602, 3902, 4202, 4502, 4802, 4822, 5412, 5703, 6303. i-FX-G05 /SL-K: 2202, 2602, 2652, 2702, 2722, 3152, 3602, 3902, 4202, 4502, 4802, 4812, 4822, 5412, 6002, 6022, 6303, 6903, 7203, 7213, 7223.
881 Cu/Cu EXTERNAL COIL	Finned coil heat exchanger made from suitably-spaced copper tubes and fins designed to ensure maximum heat exchange efficiency.	This type of coil is not subject to galvanic corrosion, being made from just one material. For further information please refer to the Guidelines "Finned coil heat exchangers and protection against corrosion", available in the download section of the website <a href="http://www.climaveneta.com">www.climaveneta.com</a> , or contact our sales department.	ALL
894 Cu PIPES/PREPAINTED ALL. FINS	Finned coil heat exchanger made from copper tubes and aluminum fins with chemical cleaning treatment to remove impurities, and then coated with protective paint with the following characteristics: - fins treated with protective polyester resin paint; - over 1000 hours of salt spray protection as per ASTM B117 (fins without cross and protected edges); - excellent resistance to UV rays.	Provide a good resistance against corrosion. For further information please refer to the Guidelines "Finned coil heat exchangers and protection against corrosion", available in the download section of the website <a href="http://www.climaveneta.com">www.climaveneta.com</a> , or contact our sales department.	ALL
895 FIN GUARD SILVER TREATM	Copper-aluminum heat exchanger coils with polyurethane paint Fin Guard Silver SB. Coil completely coated by a protective layer of polyurethane paint with the following characteristics: - polyurethane paint with metallic emulsion; - over 3000 hours of salt spray protection as per ASTM B117; - excellent resistance to UV rays; - high-pressure spray painting system.	Provide a very high resistance against corrosion, also in very aggressive environment. For further information please refer to the Guidelines "Finned coil heat exchangers and protection against corrosion", available in the download section of the website <a href="http://www.climaveneta.com">www.climaveneta.com</a> , or contact our sales department.	ALL
<b>4700 EV - HYDRONIC MODULE</b>			
4714 EV - RELAY 2 PUMPS + 0-10V SIG	Evaporator hydronic module, compatible with constant or variable flow control. The unit is provided with 2 relays and a 0-10V signal terminal to control the activation and the speed of 2 external variable speed pump. The pumps are controlled in duty/standby, with running hours equalization and changeover on device failure.	The hydronic module allows to control the external pumps with the unit controller logic.	ALL

**OPTIONS**

OPTIONS	DESCRIPTIONS	BENEFITS	AVAILABLE FOR MODELS
<b>4860</b> <b>EV - PRIMARY FLOW CONTROL</b>			
4861 EV - CONSTANT FLOW	Evaporator water flow control (plant primary circuit): constant flow. Compatible with hydronic modules without regulation devices (no pumps, no contacts), with ON/OFF regulation devices (relays) or with fixed speed pumps (codes: 4701, 4702, 4703, 4704, 4705, 4706, 4707, 4708, 4709, 4711, 4712 - hydronic modules availability depends on unit model).	The unit is set up to operate with a constant water flow in the heat exchanger (plant primary circuit). This is the only option available in case of unit without any water flow regulation devices (no pumps, no contacts), which means with water flow control provided by others. In case of unit with ON/FF regulation devices or fixed speed pumps, the unit controller manages the pump activation to reduce pump consumption.	ALL
4862 EV - CONSTANT FLOW (PARAMETER)	Evaporator water flow control (plant primary circuit): constant flow (parameter set). Compatible with hydronic modules with modulating regulation devices (0-10V signal) or with variable speed pumps (codes: 4713, 4714, 4715, 4716, 4717, 4718, 4719, 4721, 4722, 4723 - hydronic modules availability depends on unit model).	The unit is set up to operate with a constant water flow in the heat exchanger (plant primary circuit). The unit controller manages the pump activation to reduce pump consumption. The pump speed is adjusted via 0-10V signal. The option provides the possibility to set the pump speed with a controller parameter. Once set, the speed pump remains constant until the next parameter adjustment. The parameter set constant flow control is useful during the unit installation and commissioning, to adjust water flow and pressure head according to the real plant characteristics.	ALL
4864 EV - VPF (plant DP trans excl)	Evaporator water flow control (plant primary circuit): variable flow (delta P control). Only for single unit systems. Compatible with hydronic modules with modulating regulation devices (0-10V signal) or with variable speed pumps (codes: 4713, 4714, 4715, 4716, 4717, 4718, 4719, 4721, 4722, 4723 - hydronic modules availability depends on unit model). The option includes: differential pressure transducer on the unit's heat exchanger and related controller expansion board, controller expansion board to read the plant side differential pressure transducer (4-20mA signal) and manage the hydraulic by-pass valve opening (0-10V signal). Compulsory equipment, supplied by others: plant side differential pressure transducer, plant side hydraulic by-pass valve.	The unit is set up to operate with a variable water flow in the heat exchanger (plant primary circuit). The unit controller manages the pump activation to reduce pump consumption. The pump speed is adjusted via 0-10V signal. The option provides a pump speed management based on the VPF (Variable Primary Flow) function. It keeps the delta P constant on the plant side (primary circuit), thus bringing significant pump consumption reduction during part load operation. The VPF function is applicable in systems with only the primary circuit. Further information available in the dedicated bulletin section.	ALL
4865 EV - VPF (plant DP trans incl)	Evaporator water flow control (plant primary circuit): variable flow (delta P control). Only for single unit systems. Compatible with hydronic modules with modulating regulation devices (0-10V signal) or with variable speed pumps (codes: 4713, 4714, 4715, 4716, 4717, 4718, 4719, 4721, 4722, 4723 - hydronic modules availability depends on unit model). The option includes: differential pressure transducer on the unit's heat exchanger and related controller expansion board, plant side differential pressure transducer (installation by others), controller expansion board to read the plant side differential pressure transducer (4-20mA signal) and manage the hydraulic by-pass valve opening (0-10V signal). Compulsory equipment, supplied by others: plant side hydraulic by-pass valve.	The unit is set up to operate with a variable water flow in the heat exchanger (plant primary circuit). The unit controller manages the pump activation to reduce pump consumption. The pump speed is adjusted via 0-10V signal. The option provides a pump speed management based on the VPF (Variable Primary Flow) function. It keeps the delta P constant on the plant side (primary circuit), thus bringing significant pump consumption reduction during part load operation. The VPF function is applicable in systems with only the primary circuit. Further information available in the dedicated bulletin section.	ALL



**OPTIONS**

OPTIONS	DESCRIPTIONS	BENEFITS	AVAILABLE FOR MODELS
<p>4866 EV - VPF MULTI-UNIT SYSTEM</p>	<p>Evaporator water flow control (plant primary circuit): variable flow (delta P control). Only for multi-unit systems. Compatible with hydronic modules with modulating regulation devices (0-10V signal) or with variable speed pumps (codes: 4713, 4714, 4715, 4716, 4717, 4718, 4719, 4721, 4722, 4723 - hydronic modules availability depends on unit model). The option includes: differential pressure transducer on the unit's heat exchanger and related controller expansion board. It shall be the customer responsibility to configure the multi-unit control system (Manager3000 or ClimaPRO) with option VPF.</p>	<p>The unit is set up to operate with a variable water flow in the heat exchanger (plant primary circuit). The unit controller manages the pump activation to reduce pump consumption. The pump speed is adjusted via 0-10V signal. The option provides a pump speed management based on the VPF (Variable Primary Flow) function. It keeps the delta P constant on the plant side (primary circuit), thus bringing significant pump consumption reduction during part load operation. The VPF function is applicable in systems with only the primary circuit. Further information available in the dedicated bulletin section.</p>	<p>ALL</p>
<p>4867 EV - VPF.D</p>	<p>Evaporator water flow control (plant primary circuit): variable flow (delta T control). Only for single unit systems. Compatible with hydronic modules with modulating regulation devices (0-10V signal) or with variable speed pumps (codes: 4713, 4714, 4715, 4716, 4717, 4718, 4719, 4721, 4722, 4723 - hydronic modules availability depends on unit model). The option includes: 2 plant side NTC temperature sensors (installation by others).</p>	<p>The unit is set up to operate with a variable water flow in the heat exchanger (plant primary circuit). The unit controller manages the pump activation to reduce pump consumption. The pump speed is adjusted via 0-10V signal. The option provides a pump speed management based on the VPF.D (Variable Primary Flow with Decoupler) function. It keeps the delta T constant on the plant side (primary circuit), thus bringing significant pump consumption reduction during part load operation. The VPF.D function is applicable in systems with the primary and secondary circuits separated by a hydraulic decoupler. Further information available in the dedicated bulletin section.</p>	<p>ALL</p>
<p>4868 EV - VPF.D MULTI-UNIT SYSTEM</p>	<p>Evaporator water flow control (plant primary circuit): variable flow (delta T control). Only for multi-unit systems. Compatible with hydronic modules with modulating regulation devices (0-10V signal) or with variable speed pumps (codes: 4713, 4714, 4715, 4716, 4717, 4718, 4719, 4721, 4722, 4723 - hydronic modules availability depends on unit model). It shall be the customer responsibility to configure the multi-unit control system (Manager3000 or ClimaPRO) with option VPF.D.</p>	<p>The unit is set up to operate with a variable water flow in the heat exchanger (plant primary circuit). The unit controller manages the pump activation to reduce pump consumption. The pump speed is adjusted via 0-10V signal. The option provides a pump speed management based on the VPF.D (Variable Primary Flow with Decoupler) function. It keeps the delta T constant on the plant side (primary circuit), thus bringing significant pump consumption reduction during part load operation. The VPF.D function is applicable in systems with the primary and secondary circuits separated by a hydraulic decoupler. Further information available in the dedicated bulletin section.</p>	<p>ALL</p>

## OPTIONS

OPTIONS	DESCRIPTIONS	BENEFITS	AVAILABLE FOR MODELS
4869 EV - VPF.E	Evaporator water flow control (plant primary circuit): variable flow (delta T control). Compatible with hydronic modules with modulating regulation devices (0-10V signal) or with variable speed pumps (codes: 4713, 4714, 4715, 4716, 4717, 4718, 4719, 4721, 4722, 4723 - hydronic modules availability depends on unit model).	The unit is set up to operate with a variable water flow in the heat exchanger (plant primary circuit). The unit controller manages the pump activation to reduce pump consumption. The pump speed is adjusted via 0-10V signal. The option provides a pump speed management based on the VPF.E function. It keeps the delta T constant on the plant side (primary circuit), thus bringing significant pump consumption reduction during part load operation. The VPF.E function is applicable in systems with only the primary circuit and with the hydraulic terminals equipped 3 way valve (by-pass). Further information available in the dedicated bulletin section.	ALL
<b>2910 HYDRAULIC CONNECTIONS</b>			
2911 FLANGED HYDRAULIC CONNECTIONS	Grooved coupling with flanged counter-pipe user/source side.		ALL
<b>2430 PIPING KIT ANTIFREEZE HEATER</b>			
2432 ANTIFREEZE PIPING, PUMPS	Electrical heaters on pipes and other hydraulic unit's components. This option is mandatory if the unit is supposed to work with outdoor temperature below 0°C.	It protects the unit against ice formation on its hydraulic components.	ALL
<b>2680 WATER CONNECTIONS ORIENTATION</b>			
2685 EVAP. CONNECTION RIGHT HAND SIDE			ALL
2686 EVAP. CONNECTION LEFT HAND SIDE			ALL
<b>2340 UNIT ENCLOSURE</b>			
2315 NOISE REDUCER	The option includes the fan speed reduction and the compressors' acoustical enclosure	The dedicated fans' speed calibration together with the soundproofing of the most critical components permit a significant noise reduction (for the precise performance of the unit with the Noise Reducer kit please refer to the selection software ELCA Studio).	ALL
<b>2020 ANTI-INTRUSION GRILLS</b>			
2021 ANTI-INTRUSION GRILLS	Anti-intrusions grills	Avoid the intrusion of solid bodies into the unit's structure.	ALL
<b>2100 ANTIVIBRATION MOUNTING</b>			
2101 RUBBER TYPE ANTIVIBR.MOUNTING			ALL
2102 SPRING TYPE ANTIVIBR.MOUNTING			ALL
<b>1970 LONG DISTANCE TRANSPORTATION</b>			
1971 REINFORCING BARS	Bars used to reinforce the structure	Improve resistance during long transportation	ALL
<b>9970 PACKING</b>			
9966 NYLON PACKING	Unit covered with nylon		ALL



## OPTIONS

OPTIONS	DESCRIPTIONS	BENEFITS	AVAILABLE FOR MODELS
9979 CONTAINER PACKING	Unit provided with container slides and covered with nylon		ALL

**OPTIONS**

**Additional information - IMPORTANT -**

**1561 - Double power supply (ATS)**

In some units, the transfer switch requires an enlarged electrical board. This entails a unit length increase. For further information, please contact our sales department.

**1562 - Double power supply (motorized changeover)**

These accessories entail the substitution of the standard general lock door isolator with a door microswitch that switches the changeover to 0 position (open). In some units, the transfer switch requires an enlarged electrical board. This entails a unit length increase. For further information, please contact our sales department.

**1015 - Heat exchangers NSW certified**

**1019 - Heat exchangers AS1210 certified**

The certification is available for the evaporator only. If the certification is required also for the recovery heat exchanger (versions /D and /R), please contact our sales department.

**4501 - Fast restart (UPS excluded)**

In some units, the transfer switch requires an enlarged electrical board. This entails a unit length increase. For further information, please contact our sales department.

**4502 - Fast restart (UPS included)**

The following tables show the first compressor start-up time and ramp-up time for 100% cooling capacity.

The time frames shown in Table 1 and 2 are defined by the power restoration.

Table 1 - First compressor start-up time

Standard unit <sup>(1)</sup>	Unit with fast restart <sup>(1)</sup>
5' 40"	85"

(1) Minimum time from its previous start-up and minimum off-time need to be fulfilled to start the compressor.

Table 2 - Ramp-up time for 100% cooling capacity

Compressor number	Standard unit <sup>(2)(3)</sup>	Unit with fast restart <sup>(2)(3)</sup>
2	10' 50"	3' 00"
3	12' 40"	3' 10"

(2) Reference conditions: plant (side) cooling exchanger water (in/out) 12°C / 7°C; Source (side) heat exchanger air (in) 35°C.

(3) Minimum time from their previous start-up and minimum off-time need to be fulfilled to start the compressors.

With the fast restart, each compressor can only start after 15' from its previous start-up and 1' 30" of off-time.

Without the fast restart, each compressor can only start after 15' from its previous start-up and 5' 00" of off-time.

The fast restart can be activated only 2 times every 24 hours. It is possible to request the fast restart activation for 4 times every 24 hours (in this case the minimum off-time of each compressor will increase from 1' 30" to 2' 30"). For further information, please contact our sales department.

When the maximum number of fast restarts in a single 24 hour period is reached, the fast restart function is disabled and other potential restarts will follow the standard timing. Once the 24 hours have passed, the fast restart function is automatically

enabled again.

In some units, the transfer switch requires an enlarged electrical board. This entails a unit length increase. For further information, please contact our sales department.

**1955 - Kit HT**

Available for /A and /SL-A versions.

Full load operating limits: 50°C outdoor air temperature

Part load operating limits: 55°C outdoor air temperature

Consult the selection software for the specific operating envelopes of each unit.

**808 - EC fans**

These fans are suitable to operate up to 46°C of outdoor temperature. In case of higher temperatures, fans with oversized motors must be used. For the quotation of these components, please contact our sales department.

**1801 - Evaporator water flow switch**

The accessory is supplied loose.

**2315 - Noise Reducer**

Soundproofing insulation characteristics: multilayer lining of polyurethane foam and sound-insulating gaiter, total thickness 32 mm.

Fan speed reduction.

Sound power reduction: -3 dB(A).

**2340 – Without enclosure**

This option, available for non-silenced versions, leads to a sound power increase of 3 dB(A).

**0113 - Reg.2015/1095 SEPR MT compliant**

/K and SL/K versions: this option requires the option 808 – EC fans to guarantee the operation in the working conditions established by EU Regulation 2015/1095.

**4864 - EV - VPF (plant DP trans excl)**

**4865 - EV - VPF (plant DP trans incl)**

**4866 - EV - VPF multi-unit system**

With these accessories, the minimum leaving water temperature admitted is 5°C.

**4867 - EV - VPF.D**

**4868 - EV - VPF.D multi-unit system**

With these accessories, the minimum leaving water temperature admitted is 5°C.

**OPTIONS**

**3371 - D - Relay 1 pump (ON/OFF)**

The operating diagram of the device is provided below.

Figure 1 - Operating diagram of the “partial heat recovery control” device for a unit with two refrigerant circuits.

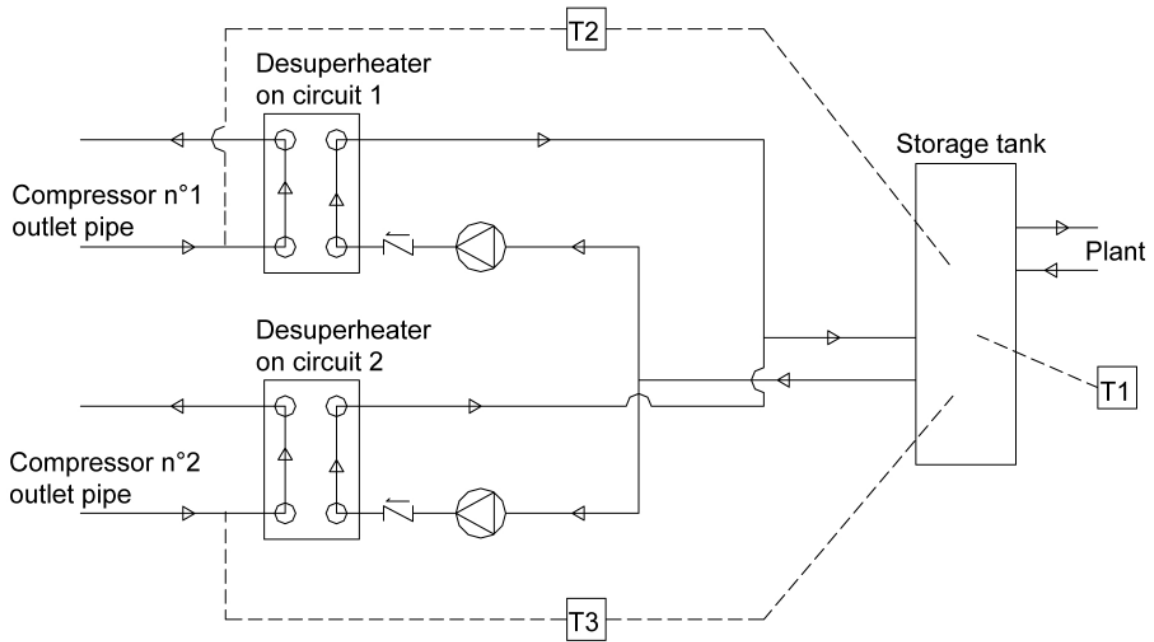

Note: the thermostats T1, T2 and T3 are supplied cabled. It is the customer's responsibility to place the temperature probes in the storage.

## OPTIONS

### Chiller Plant Control with Active Optimization System

#### ClimaPRO System Manager

ClimaPRO System Manager represents the state-of-the-art platform for chiller plant management and control.

ClimaPRO ensures to actively optimize the entire chiller plant by managing and adjusting each component directly involved in the production and the distribution of the heating and the cooling energies, therefore involving chillers and heat pumps, pumping groups as well as the source-side devices like, for example, the cooling towers.

In particular, ClimaPRO measures in real-time all the operating variables from the field, for each individual device and each of the main system branches, by using serial communication lines as well as dedicated analogue signals.

The acquired data are then compared with the design data of each single unit at any different working conditions, thus allowing to implement control strategies based on dynamic algorithms which take into account the real operating conditions.

On the basis of these values, an advanced diagnostic module also allows to assess the level of efficiency for each individual unit, translating data into easy-to-read information in order to simplify and optimize the maintenance activities.

The "Chart Builder" software module allows to display the trends of the main operating variables. The "Reporting" module allows to send reports to selected users, including data and system's status of the main devices as well as to perform calculation of the energy indexes for each single unit and for the entire chiller plant.

The accessibility to ClimaPRO System Manager is ensured by an integrated web server that makes it visible from any computer equipped with a web browser, either locally or remotely.



## 4.1 GENERAL TECHNICAL DATA

## i-FR-G05-Z/K

[ SI System ]

i-FR-G05-Z/K		2202	2602	2652	2702	2722	3152	3602	3902	4202	4502	
Power supply		V/ph/Hz 400/3/50 400/3/50 400/3/50 400/3/50 400/3/50 400/3/50 400/3/50 400/3/50 400/3/50 400/3/50 400/3/50										
<b>PERFORMANCE</b>												
<b>COOLING ONLY (GROSS VALUE)</b>												
Cooling capacity	(1)	kW	478,6	531,1	561,2	598,1	656,7	720,7	801,4	874,1	932,0	990,3
Total power input	(1)	kW	172,0	189,2	198,6	209,1	237,2	263,0	290,3	312,1	331,0	358,1
EER	(1)	kW/kW	2,783	2,807	2,826	2,860	2,769	2,740	2,761	2,801	2,816	2,765
ESEER	(1)	kW/kW	4,660	4,670	4,670	4,630	4,630	4,720	4,700	4,610	4,620	4,670
<b>COOLING ONLY (EN14511 VALUE)</b>												
Cooling capacity	(1)(2)	kW	477,3	529,4	559,6	596,2	654,7	718,2	798,9	871,3	928,7	987,3
EER	(1)(2)	kW/kW	2,750	2,770	2,800	2,830	2,740	2,710	2,730	2,770	2,780	2,730
ESEER	(1)(2)	kW/kW	4,480	4,460	4,480	4,430	4,430	4,490	4,490	4,410	4,400	4,480
Cooling energy class			C	C	C	C	C	C	C	C	C	C
<b>EXCHANGERS</b>												
<b>HEAT EXCHANGER USER SIDE IN REFRIGERATION</b>												
Water flow	(1)	l/s	22,89	25,40	26,84	28,60	31,40	34,47	38,33	41,80	44,57	47,36
Pressure drop	(1)	kPa	32,0	39,5	35,2	40,0	38,3	46,2	40,7	42,8	48,7	42,4
<b>REFRIGERANT CIRCUIT</b>												
Compressors nr.		N°	2	2	2	2	2	2	2	2	2	2
Number of capacity steps		N°	0	0	0	0	0	0	0	0	0	0
No. Circuits		N°	2	2	2	2	2	2	2	2	2	2
Regulation			STEPLESS	STEPLESS	STEPLESS	STEPLESS	STEPLESS	STEPLESS	STEPLESS	STEPLESS	STEPLESS	STEPLESS
Min. capacity step		%	-	-	-	-	-	-	-	-	-	-
Refrigerant			R513A	R513A	R513A	R513A	R513A	R513A	R513A	R513A	R513A	R513A
Refrigerant charge		kg	79,0	87,0	92,0	101	108	120	135	146	155	161
Oil charge		kg	36,0	36,0	36,0	36,0	36,0	36,0	36,0	36,0	36,0	53,0
Rc (ASHRAE)	(3)	kg/kW	0,17	0,17	0,17	0,17	0,17	0,17	0,17	0,17	0,17	0,16
<b>FANS</b>												
Fans number		N°	6	7	7	8	8	9	10	11	12	12
Air flow		m³/s	31,90	37,22	37,22	42,53	42,53	47,85	53,17	58,48	63,80	63,80
Fans power input		kW	1,90	1,90	1,90	1,90	1,90	1,90	1,90	1,90	1,90	1,90
<b>NOISE LEVEL</b>												
Sound Pressure	(4)	dB(A)	67	68	68	68	69	68	68	69	70	70
Sound power level in cooling	(5)(6)	dB(A)	99	100	100	100	101	101	101	102	103	103
<b>SIZE AND WEIGHT</b>												
A	(7)	mm	4150	5400	5400	5400	5400	6650	6650	7900	7900	7900
B	(7)	mm	2260	2260	2260	2260	2260	2260	2260	2260	2260	2260
H	(7)	mm	2500	2500	2500	2500	2500	2500	2500	2500	2500	2500
Operating weight	(7)	kg	4790	5270	5280	5330	5720	6210	6270	6700	6740	7350

**Notes:**

1 Plant (side) cooling exchanger water (in/out) 12,00°C/7,00°C; Source (side) heat exchanger air (in) 35,0°C.

2 Values in compliance with EN14511

3 Rated in accordance with AHRI Standard 550/590 (2011 with addendum 1).

4 Average sound pressure level at 10m distance, unit in a free field on a reflective surface; non-binding value calculated from the sound power level.

5 Sound power on the basis of measurements made in compliance with ISO 9614.

6 Sound power level in cooling, outdoors.

7 Unit in standard configuration/execution, without optional accessories.

- Not available

Certified data in EUROVENT

**GENERAL TECHNICAL DATA**

**i-FR-G05-Z/K**

[ SI System ]

i-FR-G05-Z/K		4802	4812	4822	5412	6002	6022	6303	6903	7203	7213	
Power supply		V/ph/Hz 400/3/50 400/3/50 400/3/50 400/3/50 400/3/50 400/3/50 400/3/50 400/3/50 400/3/50 400/3/50										
<b>PERFORMANCE</b>												
<b>COOLING ONLY (GROSS VALUE)</b>												
Cooling capacity	(1)	kW	1029	1054	1128	1169	1242	1302	1409	1493	1559	1649
Total power input	(1)	kW	383,8	366,8	405,3	430,5	438,8	477,1	498,8	544,8	578,9	596,2
EER	(1)	kW/kW	2,681	2,874	2,783	2,715	2,830	2,729	2,825	2,740	2,693	2,766
ESEER	(1)	kW/kW	4,730	4,650	4,650	4,790	4,810	4,810	4,610	4,660	4,660	4,620
<b>COOLING ONLY (EN14511 VALUE)</b>												
Cooling capacity	(1)(2)	kW	1026	1050	1124	1166	1238	1297	1405	1488	1555	1644
EER	(1)(2)	kW/kW	2,650	2,840	2,750	2,690	2,800	2,690	2,790	2,710	2,670	2,740
ESEER	(1)(2)	kW/kW	4,520	4,430	4,430	4,590	4,580	4,560	4,410	4,440	4,480	4,430
Cooling energy class			D	C	C	D	C	D	C	C	D	C
<b>EXCHANGERS</b>												
<b>HEAT EXCHANGER USER SIDE IN REFRIGERATION</b>												
Water flow	(1)	l/s	49,20	50,41	53,94	55,90	59,42	62,28	67,38	71,40	74,58	78,86
Pressure drop	(1)	kPa	45,8	48,1	51,7	41,7	47,1	51,8	45,9	51,5	39,6	44,3
<b>REFRIGERANT CIRCUIT</b>												
Compressors nr.		N°	2	2	2	2	2	2	3	3	3	3
Number of capacity steps		N°	0	0	0	0	0	0	0	0	0	0
No. Circuits		N°	2	2	2	2	2	2	3	3	3	3
Regulation			STEPLESS	STEPLESS	STEPLESS	STEPLESS	STEPLESS	STEPLESS	STEPLESS	STEPLESS	STEPLESS	STEPLESS
Min. capacity step		%	-	-	-	-	-	-	-	-	-	-
Refrigerant			R513A	R513A	R513A	R513A	R513A	R513A	R513A	R513A	R513A	R513A
Refrigerant charge		kg	168	174	189	193	208	214	236	244	254	273
Oil charge		kg	70,0	70,0	70,0	70,0	70,0	70,0	54,0	88,0	105	105
Rc (ASHRAE)	(3)	kg/kW	0,16	0,17	0,17	0,17	0,17	0,17	0,17	0,17	0,16	0,17
<b>FANS</b>												
Fans number		N°	12	14	14	14	16	16	18	18	18	20
Air flow		m³/s	63,80	74,43	74,43	74,43	85,07	85,07	95,70	95,70	95,70	106,33
Fans power input		kW	1,90	1,90	1,90	1,90	1,90	1,90	1,90	1,90	1,90	1,90
<b>NOISE LEVEL</b>												
Sound Pressure	(4)	dB(A)	71	71	72	72	72	72	72	72	72	73
Sound power level in cooling	(5)(6)	dB(A)	104	104	105	105	105	105	105	105	105	106
<b>SIZE AND WEIGHT</b>												
A	(7)	mm	7900	9150	9150	9150	10400	10400	11650	11650	11650	12900
B	(7)	mm	2260	2260	2260	2260	2260	2260	2260	2260	2260	2260
H	(7)	mm	2500	2500	2500	2500	2500	2500	2500	2500	2500	2500
Operating weight	(7)	kg	7750	8220	8340	8500	8890	9000	10650	11460	11840	12350

Notes:

- 1 Plant (side) cooling exchanger water (in/out) 12,00°C/7,00°C; Source (side) heat exchanger air (in) 35,0°C.
- 2 Values in compliance with EN14511
- 3 Rated in accordance with AHRI Standard 550/590 (2011 with addendum 1).
- 4 Average sound pressure level at 10m distance, unit in a free field on a reflective surface; non-binding value calculated from the sound power level.
- 5 Sound power on the basis of measurements made in compliance with ISO 9614.
- 6 Sound power level in cooling, outdoors.
- 7 Unit in standard configuration/execution, without optional accessories.

- Not available

Certified data in EUROVENT

**GENERAL TECHNICAL DATA**

**i-FR-G05-Z/K**

[ SI System ]

<b>i-FR-G05-Z/K</b>		<b>7223</b>	
Power supply		V/ph/Hz	400/3/50
<b>PERFORMANCE</b>			
<b>COOLING ONLY (GROSS VALUE)</b>			
Cooling capacity	(1)	kW	1697
Total power input	(1)	kW	618,5
EER	(1)	kW/kW	2,744
ESEER	(1)	kW/kW	4,650
<b>COOLING ONLY (EN14511 VALUE)</b>			
Cooling capacity	(1)(2)	kW	1691
EER	(1)(2)	kW/kW	2,710
ESEER	(1)(2)	kW/kW	4,430
Cooling energy class			C
<b>EXCHANGERS</b>			
<b>HEAT EXCHANGER USER SIDE IN REFRIGERATION</b>			
Water flow	(1)	l/s	81,17
Pressure drop	(1)	kPa	50,4
<b>REFRIGERANT CIRCUIT</b>			
Compressors nr.		N°	3
Number of capacity steps		N°	0
No. Circuits		N°	3
Regulation			STEPLESS
Min. capacity step		%	-
Refrigerant			R513A
Refrigerant charge		kg	288
Oil charge		kg	105
Rc (ASHRAE)	(3)	kg/kW	0,17
<b>FANS</b>			
Fans number		N°	20
Air flow		m³/s	106,33
Fans power input		kW	1,90
<b>NOISE LEVEL</b>			
Sound Pressure	(4)	dB(A)	73
Sound power level in cooling	(5)(6)	dB(A)	106
<b>SIZE AND WEIGHT</b>			
A	(7)	mm	12900
B	(7)	mm	2260
H	(7)	mm	2500
Operating weight	(7)	kg	12430

Notes:

- 1 Plant (side) cooling exchanger water (in/out) 12,00°C/7,00°C; Source (side) heat exchanger air (in) 35,0°C.
- 2 Values in compliance with EN14511
- 3 Rated in accordance with AHRI Standard 550/590 (2011 with addendum 1).
- 4 Average sound pressure level at 10m distance, unit in a free field on a reflective surface; non-binding value calculated from the sound power level.
- 5 Sound power on the basis of measurements made in compliance with ISO 9614.
- 6 Sound power level in cooling, outdoors.
- 7 Unit in standard configuration/execution, without optional accessories.

- Not available

Certified data in EUROVENT

**GENERAL TECHNICAL DATA**

**i-FR-G05-Z/SL-K**

[ SI System ]

i-FR-G05-Z/SL-K		2202	2602	2652	2702	2722	3152	3602	3902	4202	4502	
Power supply		V/ph/Hz 400/3/50 400/3/50 400/3/50 400/3/50 400/3/50 400/3/50 400/3/50 400/3/50 400/3/50 400/3/50										
<b>PERFORMANCE</b>												
<b>COOLING ONLY (GROSS VALUE)</b>												
Cooling capacity	(1)	kW	477,0	516,7	554,6	578,0	662,9	711,3	774,2	845,6	903,1	972,7
Total power input	(1)	kW	168,1	177,0	195,5	212,2	228,3	260,2	295,6	317,7	336,9	356,8
EER	(1)	kW/kW	2,838	2,919	2,837	2,724	2,904	2,734	2,619	2,662	2,681	2,726
ESEER	(1)	kW/kW	4,810	4,800	4,770	4,660	4,750	4,760	4,750	4,640	4,640	4,760
<b>COOLING ONLY (EN14511 VALUE)</b>												
Cooling capacity	(1)(2)	kW	475,7	515,1	553,0	576,3	660,9	708,9	772,0	843,1	900,1	969,8
EER	(1)(2)	kW/kW	2,810	2,880	2,810	2,690	2,870	2,700	2,590	2,630	2,650	2,700
ESEER	(1)(2)	kW/kW	4,480	4,590	4,570	4,470	4,560	4,540	4,560	4,450	4,430	4,560
Cooling energy class			C	C	C	D	C	C	D	D	D	C
<b>EXCHANGERS</b>												
<b>HEAT EXCHANGER USER SIDE IN REFRIGERATION</b>												
Water flow	(1)	l/s	22,81	24,71	26,52	27,64	31,70	34,02	37,02	40,44	43,19	46,52
Pressure drop	(1)	kPa	31,8	37,4	34,4	37,3	39,1	45,0	38,0	40,1	45,7	40,9
<b>REFRIGERANT CIRCUIT</b>												
Compressors nr.		N°	2	2	2	2	2	2	2	2	2	2
Number of capacity steps		N°	0	0	0	0	0	0	0	0	0	0
No. Circuits		N°	2	2	2	2	2	2	2	2	2	2
Regulation			STEPLESS	STEPLESS	STEPLESS	STEPLESS	STEPLESS	STEPLESS	STEPLESS	STEPLESS	STEPLESS	STEPLESS
Min. capacity step		%	-	-	-	-	-	-	-	-	-	-
Refrigerant			R513A	R513A	R513A	R513A	R513A	R513A	R513A	R513A	R513A	R513A
Refrigerant charge		kg	83,0	91,0	97,0	101	116	125	135	146	155	168
Oil charge		kg	36,0	36,0	36,0	36,0	36,0	36,0	36,0	36,0	36,0	53,0
Rc (ASHRAE)	(3)	kg/kW	0,18	0,18	0,18	0,18	0,18	0,18	0,18	0,17	0,17	0,17
<b>FANS</b>												
Fans number		N°	7	8	8	8	10	10	10	11	12	13
Air flow		m³/s	33,61	38,41	38,41	38,41	48,02	48,02	48,02	52,82	57,62	62,42
Fans power input		kW	1,40	1,40	1,40	1,40	1,40	1,40	1,40	1,40	1,40	1,40
<b>NOISE LEVEL</b>												
Sound Pressure	(4)	dB(A)	60	61	61	61	61	61	61	62	63	63
Sound power level in cooling	(5)(6)	dB(A)	92	93	93	93	94	94	94	95	96	96
<b>SIZE AND WEIGHT</b>												
A	(7)	mm	5400	5400	5400	5400	6650	6650	6650	7900	7900	9150
B	(7)	mm	2260	2260	2260	2260	2260	2260	2260	2260	2260	2260
H	(7)	mm	2500	2500	2500	2500	2500	2500	2500	2500	2500	2500
Operating weight	(7)	kg	5450	5600	5620	5650	6560	6580	6590	7050	7100	8110

Notes:

- 1 Plant (side) cooling exchanger water (in/out) 12,00°C/7,00°C; Source (side) heat exchanger air (in) 35,0°C.
- 2 Values in compliance with EN14511
- 3 Rated in accordance with AHRI Standard 550/590 (2011 with addendum 1).
- 4 Average sound pressure level at 10m distance, unit in a free field on a reflective surface; non-binding value calculated from the sound power level.
- 5 Sound power on the basis of measurements made in compliance with ISO 9614.
- 6 Sound power level in cooling, outdoors.
- 7 Unit in standard configuration/execution, without optional accessories.

- Not available

Certified data in EUROVENT



**GENERAL TECHNICAL DATA**

**i-FR-G05-Z/SL-K**

[ SI System ]

<b>i-FR-G05-Z/SL-K</b>		<b>4802</b>	<b>4812</b>	<b>4822</b>	<b>5412</b>	<b>6002</b>	<b>6022</b>	<b>6303</b>	<b>6903</b>	<b>7203</b>	<b>7213</b>	
Power supply		V/ph/Hz 400/3/50 400/3/50 400/3/50 400/3/50 400/3/50 400/3/50 400/3/50 400/3/50 400/3/50 400/3/50										
<b>PERFORMANCE</b>												
<b>COOLING ONLY (GROSS VALUE)</b>												
Cooling capacity	(1)	kW	1028	1046	1120	1162	1199	1290	1365	1474	1541	1590
Total power input	(1)	kW	373,5	359,4	397,2	422,1	446,5	470,5	507,7	541,1	572,2	610,0
EER	(1)	kW/kW	2,752	2,910	2,820	2,753	2,685	2,742	2,689	2,724	2,693	2,607
ESEER	(1)	kW/kW	4,850	4,740	4,800	4,880	4,880	4,880	4,760	4,880	4,810	4,800
<b>COOLING ONLY (EN14511 VALUE)</b>												
Cooling capacity	(1)(2)	kW	1025	1042	1116	1159	1195	1286	1361	1469	1537	1586
EER	(1)(2)	kW/kW	2,720	2,870	2,780	2,720	2,660	2,710	2,660	2,690	2,670	2,580
ESEER	(1)(2)	kW/kW	4,610	4,530	4,560	4,670	4,660	4,630	4,570	4,650	4,630	4,610
Cooling energy class			C	C	C	C	D	C	D	D	D	D
<b>EXCHANGERS</b>												
<b>HEAT EXCHANGER USER SIDE IN REFRIGERATION</b>												
Water flow	(1)	l/s	49,15	50,01	53,58	55,57	57,32	61,67	65,28	70,50	73,70	76,02
Pressure drop	(1)	kPa	45,7	47,3	51,0	41,2	43,9	50,8	43,1	50,2	38,7	41,2
<b>REFRIGERANT CIRCUIT</b>												
Compressors nr.		N°	2	2	2	2	2	2	3	3	3	3
Number of capacity steps		N°	0	0	0	0	0	0	0	0	0	0
No. Circuits		N°	2	2	2	2	2	2	3	3	3	3
Regulation			STEPLESS	STEPLESS	STEPLESS	STEPLESS	STEPLESS	STEPLESS	STEPLESS	STEPLESS	STEPLESS	STEPLESS
Min. capacity step		%	-	-	-	-	-	-	-	-	-	-
Refrigerant			R513A	R513A	R513A	R513A	R513A	R513A	R513A	R513A	R513A	R513A
Refrigerant charge		kg	178	183	198	204	208	224	236	255	267	278
Oil charge		kg	70,0	70,0	70,0	70,0	70,0	70,0	54,0	88,0	105	105
Rc (ASHRAE)	(3)	kg/kW	0,18	0,18	0,18	0,18	0,18	0,18	0,17	0,17	0,17	0,18
<b>FANS</b>												
Fans number		N°	14	16	16	16	16	18	18	20	20	20
Air flow		m³/s	67,22	76,83	76,83	76,83	76,83	86,43	86,43	96,03	96,03	96,03
Fans power input		kW	1,40	1,40	1,40	1,40	1,40	1,40	1,40	1,40	1,40	1,40
<b>NOISE LEVEL</b>												
Sound Pressure	(4)	dB(A)	63	63	63	63	63	63	63	63	63	64
Sound power level in cooling	(5)(6)	dB(A)	96	96	96	96	96	96	96	96	96	97
<b>SIZE AND WEIGHT</b>												
A	(7)	mm	9150	10400	10400	10400	10400	11650	11650	12900	12900	12900
B	(7)	mm	2260	2260	2260	2260	2260	2260	2260	2260	2260	2260
H	(7)	mm	2500	2500	2500	2500	2500	2500	2500	2500	2500	2500
Operating weight	(7)	kg	8550	9010	9130	9310	9270	9790	11140	12390	12770	12850

Notes:

- 1 Plant (side) cooling exchanger water (in/out) 12,00°C/7,00°C; Source (side) heat exchanger air (in) 35,0°C.
- 2 Values in compliance with EN14511
- 3 Rated in accordance with AHRI Standard 550/590 (2011 with addendum 1).
- 4 Average sound pressure level at 10m distance, unit in a free field on a reflective surface; non-binding value calculated from the sound power level.
- 5 Sound power on the basis of measurements made in compliance with ISO 9614.
- 6 Sound power level in cooling, outdoors.
- 7 Unit in standard configuration/execution, without optional accessories.
- Not available

Certified data in EUROVENT

**GENERAL TECHNICAL DATA**

**i-FR-G05-Z/SL-K**

[ SI System ]

<b>i-FR-G05-Z/SL-K</b>		<b>7223</b>	
Power supply		V/ph/Hz	400/3/50
<b>PERFORMANCE</b>			
<b>COOLING ONLY (GROSS VALUE)</b>			
Cooling capacity	(1)	kW	1635
Total power input	(1)	kW	633,6
EER	(1)	kW/kW	2,580
ESEER	(1)	kW/kW	4,810
<b>COOLING ONLY (EN14511 VALUE)</b>			
Cooling capacity	(1)(2)	kW	1630
EER	(1)(2)	kW/kW	2,550
ESEER	(1)(2)	kW/kW	4,610
Cooling energy class			D
<b>EXCHANGERS</b>			
<b>HEAT EXCHANGER USER SIDE IN REFRIGERATION</b>			
Water flow	(1)	l/s	78,18
Pressure drop	(1)	kPa	46,7
<b>REFRIGERANT CIRCUIT</b>			
Compressors nr.		N°	3
Number of capacity steps		N°	0
No. Circuits		N°	3
Regulation			STEPLESS
Min. capacity step		%	-
Refrigerant			R513A
Refrigerant charge		kg	288
Oil charge		kg	105
Rc (ASHRAE)	(3)	kg/kW	0,18
<b>FANS</b>			
Fans number		N°	20
Air flow		m³/s	96,03
Fans power input		kW	1,40
<b>NOISE LEVEL</b>			
Sound Pressure	(4)	dB(A)	64
Sound power level in cooling	(5)(6)	dB(A)	97
<b>SIZE AND WEIGHT</b>			
A	(7)	mm	12900
B	(7)	mm	2260
H	(7)	mm	2500
Operating weight	(7)	kg	12930

Notes:

- 1 Plant (side) cooling exchanger water (in/out) 12,00°C/7,00°C; Source (side) heat exchanger air (in) 35,0°C.
- 2 Values in compliance with EN14511
- 3 Rated in accordance with AHRI Standard 550/590 (2011 with addendum 1).
- 4 Average sound pressure level at 10m distance, unit in a free field on a reflective surface; non-binding value calculated from the sound power level.
- 5 Sound power on the basis of measurements made in compliance with ISO 9614.
- 6 Sound power level in cooling, outdoors.
- 7 Unit in standard configuration/execution, without optional accessories.

- Not available

Certified data in EUROVENT

**GENERAL TECHNICAL DATA**
**i-FR-G05-Z/A**

[ SI System ]

i-FR-G05-Z/A		2202	2602	2652	2702	2722	3152	3602	3902	4202	4502	
Power supply		V/ph/Hz 400/3/50 400/3/50 400/3/50 400/3/50 400/3/50 400/3/50 400/3/50 400/3/50 400/3/50 400/3/50 400/3/50										
<b>PERFORMANCE</b>												
<b>COOLING ONLY (GROSS VALUE)</b>												
Cooling capacity	(1)	kW	510,2	551,9	590,0	626,9	684,3	767,2	839,9	899,4	959,4	1028
Total power input	(1)	kW	163,5	177,8	189,4	203,0	222,2	257,2	286,0	303,4	320,6	340,0
EER	(1)	kW/kW	3,120	3,104	3,115	3,088	3,080	2,983	2,937	2,964	2,993	3,024
ESEER	(1)	kW/kW	5,080	5,200	5,160	5,060	5,050	5,040	5,070	5,060	5,080	5,090
<b>COOLING ONLY (EN14511 VALUE)</b>												
Cooling capacity	(1)(2)	kW	508,7	550,4	588,2	624,8	682,1	765,0	837,1	896,4	955,9	1025
EER	(1)(2)	kW/kW	3,080	3,070	3,080	3,050	3,040	2,950	2,900	2,930	2,950	2,980
ESEER	(1)(2)	kW/kW	4,860	4,980	4,920	4,810	4,820	4,830	4,810	4,810	4,810	4,840
Cooling energy class			B	B	B	B	B	B	B	B	B	B
<b>EXCHANGERS</b>												
<b>HEAT EXCHANGER USER SIDE IN REFRIGERATION</b>												
Water flow	(1)	l/s	24,40	26,39	28,22	29,98	32,73	36,69	40,16	43,01	45,88	49,16
Pressure drop	(1)	kPa	36,4	34,0	38,9	43,9	41,6	37,3	44,7	45,3	51,6	45,7
<b>REFRIGERANT CIRCUIT</b>												
Compressors nr.		N°	2	2	2	2	2	2	2	2	2	2
Number of capacity steps		N°	0	0	0	0	0	0	0	0	0	0
No. Circuits		N°	2	2	2	2	2	2	2	2	2	2
Regulation			STEPLESS	STEPLESS	STEPLESS	STEPLESS	STEPLESS	STEPLESS	STEPLESS	STEPLESS	STEPLESS	STEPLESS
Min. capacity step		%	-	-	-	-	-	-	-	-	-	-
Refrigerant			R513A	R513A	R513A	R513A	R513A	R513A	R513A	R513A	R513A	R513A
Refrigerant charge		kg	91,0	93,0	100	106	115	130	141	153	162	174
Oil charge		kg	36,0	36,0	36,0	36,0	36,0	36,0	36,0	36,0	36,0	53,0
Rc (ASHRAE)	(3)	kg/kW	0,18	0,17	0,17	0,17	0,17	0,17	0,17	0,17	0,17	0,17
<b>FANS</b>												
Fans number		N°	8	8	9	10	10	11	12	13	14	15
Air flow		m³/s	42,53	42,53	47,85	53,17	53,17	58,48	63,80	69,12	74,43	79,75
Fans power input		kW	1,70	1,70	1,70	1,70	1,70	1,70	1,70	1,70	1,70	1,70
<b>NOISE LEVEL</b>												
Sound Pressure	(4)	dB(A)	67	68	67	67	68	68	68	69	70	70
Sound power level in cooling	(5)(6)	dB(A)	99	100	100	100	101	101	101	102	103	103
<b>SIZE AND WEIGHT</b>												
A	(7)	mm	5400	5400	6650	6650	6650	7900	7900	9150	9150	10400
B	(7)	mm	2260	2260	2260	2260	2260	2260	2260	2260	2260	2260
H	(7)	mm	2500	2500	2500	2500	2500	2500	2500	2500	2500	2500
Operating weight	(7)	kg	5180	5240	5720	5800	6210	6620	6670	7080	7120	8110

**Notes:**

1 Plant (side) cooling exchanger water (in/out) 12,00°C/7,00°C; Source (side) heat exchanger air (in) 35,0°C.

2 Values in compliance with EN14511

3 Rated in accordance with AHRI Standard 550/590 (2011 with addendum 1).

4 Average sound pressure level at 10m distance, unit in a free field on a reflective surface; non-binding value calculated from the sound power level.

5 Sound power on the basis of measurements made in compliance with ISO 9614.

6 Sound power level in cooling, outdoors.

7 Unit in standard configuration/execution, without optional accessories.

- Not available

Certified data in EUROVENT

**GENERAL TECHNICAL DATA**

**i-FR-G05-Z/A**

[ SI System ]

<b>i-FR-G05-Z/A</b>		<b>4802</b>	<b>4822</b>	<b>5412</b>	<b>5703</b>	<b>6303</b>	<b>6603</b>	
Power supply		V/ph/Hz 400/3/50 400/3/50 400/3/50 400/3/50 400/3/50 400/3/50						
<b>PERFORMANCE</b>								
<b>COOLING ONLY (GROSS VALUE)</b>								
Cooling capacity	(1)	kW	<b>1099</b>	<b>1162</b>	<b>1230</b>	<b>1334</b>	<b>1467</b>	<b>1520</b>
Total power input	(1)	kW	358,2	388,6	401,1	452,6	493,4	518,9
EER	(1)	kW/kW	3,068	2,990	3,067	2,947	2,973	2,929
ESEER	(1)	kW/kW	5,060	5,020	5,060	5,030	4,990	5,010
<b>COOLING ONLY (EN14511 VALUE)</b>								
Cooling capacity	(1)(2)	kW	<b>1095</b>	<b>1159</b>	<b>1226</b>	<b>1330</b>	<b>1463</b>	<b>1516</b>
EER	(1)(2)	kW/kW	3,020	2,960	3,030	2,910	2,940	2,900
ESEER	(1)(2)	kW/kW	4,800	4,810	4,810	4,820	4,810	4,810
Cooling energy class			B	B	B	B	B	B
<b>EXCHANGERS</b>								
<b>HEAT EXCHANGER USER SIDE IN REFRIGERATION</b>								
Water flow	(1)	l/s	52,54	55,59	58,81	63,78	70,16	72,70
Pressure drop	(1)	kPa	50,1	41,2	46,2	41,1	35,1	37,7
<b>REFRIGERANT CIRCUIT</b>								
Compressors nr.		N°	2	2	2	3	3	3
Number of capacity steps		N°	0	0	0	0	0	0
No. Circuits		N°	2	2	2	3	3	3
Regulation			STEPLESS	STEPLESS	STEPLESS	STEPLESS	STEPLESS	STEPLESS
Min. capacity step		%	-	-	-	-	-	-
Refrigerant			R513A	R513A	R513A	R513A	R513A	R513A
Refrigerant charge		kg	185	199	209	227	260	258
Oil charge		kg	70,0	70,0	70,0	54,0	54,0	71,0
Rc (ASHRAE)	(3)	kg/kW	0,17	0,17	0,17	0,17	0,18	0,17
<b>FANS</b>								
Fans number		N°	16	16	18	19	20	20
Air flow		m³/s	85,07	85,07	95,70	101,01	106,33	106,33
Fans power input		kW	1,70	1,70	1,70	1,70	1,70	1,70
<b>NOISE LEVEL</b>								
Sound Pressure	(4)	dB(A)	71	72	72	72	72	72
Sound power level in cooling	(5)(6)	dB(A)	104	105	105	105	105	105
<b>SIZE AND WEIGHT</b>								
A	(7)	mm	10400	10400	11650	12900	12900	12900
B	(7)	mm	2260	2260	2260	2260	2260	2260
H	(7)	mm	2500	2500	2500	2500	2500	2500
Operating weight	(7)	kg	8550	8810	9280	10880	10920	11610

Notes:

- 1 Plant (side) cooling exchanger water (in/out) 12,00°C/7,00°C; Source (side) heat exchanger air (in) 35,0°C.
- 2 Values in compliance with EN14511
- 3 Rated in accordance with AHRI Standard 550/590 (2011 with addendum 1).
- 4 Average sound pressure level at 10m distance, unit in a free field on a reflective surface; non-binding value calculated from the sound power level.
- 5 Sound power on the basis of measurements made in compliance with ISO 9614.
- 6 Sound power level in cooling, outdoors.
- 7 Unit in standard configuration/execution, without optional accessories.

- Not available

Certified data in EUROVENT

**GENERAL TECHNICAL DATA**

**i-FR-G05-Z/SL-A**

[ SI System ]

i-FR-G05-Z/SL-A		2202	2602	2652	2702	2722	3152	3602	3902	4202	4502	
Power supply		V/ph/Hz 400/3/50 400/3/50 400/3/50 400/3/50 400/3/50 400/3/50 400/3/50 400/3/50 400/3/50 400/3/50										
<b>PERFORMANCE</b>												
<b>COOLING ONLY (GROSS VALUE)</b>												
Cooling capacity	(1)	kW	498,8	559,5	581,8	615,1	682,8	751,6	811,9	891,5	942,8	1016
Total power input	(1)	kW	162,3	182,7	185,5	202,2	216,8	251,1	275,3	295,2	312,4	331,8
EER	(1)	kW/kW	3,073	3,062	3,136	3,042	3,149	2,993	2,949	3,020	3,018	3,062
ESEER	(1)	kW/kW	5,110	5,110	5,150	5,080	5,100	5,060	5,080	5,080	5,080	5,120
<b>COOLING ONLY (EN14511 VALUE)</b>												
Cooling capacity	(1)(2)	kW	497,4	557,9	580,0	613,4	680,6	749,5	809,4	888,6	939,4	1013
EER	(1)(2)	kW/kW	3,040	3,030	3,100	3,010	3,110	2,960	2,910	2,980	2,980	3,020
ESEER	(1)(2)	kW/kW	4,900	4,890	4,910	4,860	4,850	4,840	4,850	4,840	4,810	4,860
Cooling energy class			B	B	A	B	A	B	B	B	B	B
<b>EXCHANGERS</b>												
<b>HEAT EXCHANGER USER SIDE IN REFRIGERATION</b>												
Water flow	(1)	l/s	23,85	26,76	27,82	29,42	32,65	35,94	38,83	42,63	45,09	48,60
Pressure drop	(1)	kPa	34,8	35,0	37,8	33,6	41,5	35,8	41,8	44,5	49,8	44,7
<b>REFRIGERANT CIRCUIT</b>												
Compressors nr.		N°	2	2	2	2	2	2	2	2	2	2
Number of capacity steps		N°	0	0	0	0	0	0	0	0	0	0
No. Circuits		N°	2	2	2	2	2	2	2	2	2	2
Regulation			STEPLESS	STEPLESS	STEPLESS	STEPLESS	STEPLESS	STEPLESS	STEPLESS	STEPLESS	STEPLESS	STEPLESS
Min. capacity step		%	-	-	-	-	-	-	-	-	-	-
Refrigerant			R513A	R513A	R513A	R513A	R513A	R513A	R513A	R513A	R513A	R513A
Refrigerant charge		kg	91,0	101	106	112	123	136	148	162	171	184
Oil charge		kg	36,0	36,0	36,0	36,0	36,0	36,0	36,0	36,0	36,0	53,0
Rc (ASHRAE)	(3)	kg/kW	0,18	0,18	0,18	0,18	0,18	0,18	0,18	0,18	0,18	0,18
<b>FANS</b>												
Fans number		N°	8	9	10	10	12	12	14	15	16	17
Air flow		m³/s	38,41	43,21	48,02	48,02	57,62	57,62	67,22	72,02	76,83	81,63
Fans power input		kW	1,10	1,10	1,10	1,10	1,10	1,10	1,10	1,10	1,10	1,10
<b>NOISE LEVEL</b>												
Sound Pressure	(4)	dB(A)	60	60	60	60	61	61	61	62	63	63
Sound power level in cooling	(5)(6)	dB(A)	92	93	93	93	94	94	94	95	96	96
<b>SIZE AND WEIGHT</b>												
A	(7)	mm	5400	6650	6650	6650	7900	7900	9150	10400	10400	11650
B	(7)	mm	2260	2260	2260	2260	2260	2260	2260	2260	2260	2260
H	(7)	mm	2500	2500	2500	2500	2500	2500	2500	2500	2500	2500
Operating weight	(7)	kg	5490	6030	6080	6400	6990	6990	7460	7860	8080	8860

Notes:

- 1 Plant (side) cooling exchanger water (in/out) 12,00°C/7,00°C; Source (side) heat exchanger air (in) 35,0°C.
- 2 Values in compliance with EN14511
- 3 Rated in accordance with AHRI Standard 550/590 (2011 with addendum 1).
- 4 Average sound pressure level at 10m distance, unit in a free field on a reflective surface; non-binding value calculated from the sound power level.
- 5 Sound power on the basis of measurements made in compliance with ISO 9614.
- 6 Sound power level in cooling, outdoors.
- 7 Unit in standard configuration/execution, without optional accessories.
- Not available

Certified data in EUROVENT

**GENERAL TECHNICAL DATA**

**i-FR-G05-Z/SL-A**

[ SI System ]

<b>i-FR-G05-Z/SL-A</b>		<b>4802</b>	<b>4822</b>	<b>5412</b>	<b>5703</b>	<b>6303</b>	
Power supply		V/ph/Hz 400/3/50 400/3/50 400/3/50 400/3/50 400/3/50					
<b>PERFORMANCE</b>							
<b>COOLING ONLY (GROSS VALUE)</b>							
Cooling capacity	(1)	kW	<b>1086</b>	<b>1149</b>	<b>1213</b>	<b>1332</b>	<b>1462</b>
Total power input	(1)	kW	350,0	380,1	393,2	456,9	493,5
EER	(1)	kW/kW	3,103	3,023	3,085	2,915	2,963
ESEER	(1)	kW/kW	5,090	5,060	5,120	5,030	5,000
<b>COOLING ONLY (EN14511 VALUE)</b>							
Cooling capacity	(1)(2)	kW	<b>1082</b>	<b>1146</b>	<b>1209</b>	<b>1328</b>	<b>1458</b>
EER	(1)(2)	kW/kW	3,060	2,990	3,050	2,880	2,930
ESEER	(1)(2)	kW/kW	4,830	4,840	4,870	4,820	4,820
Cooling energy class			B	B	B	C	B
<b>EXCHANGERS</b>							
<b>HEAT EXCHANGER USER SIDE IN REFRIGERATION</b>							
Water flow	(1)	l/s	51,92	54,96	58,00	63,72	69,92
Pressure drop	(1)	kPa	48,9	40,3	44,9	41,0	34,8
<b>REFRIGERANT CIRCUIT</b>							
Compressors nr.		N°	2	2	2	3	3
Number of capacity steps		N°	0	0	0	0	0
No. Circuits		N°	2	2	2	3	3
Regulation			STEPLESS	STEPLESS	STEPLESS	STEPLESS	STEPLESS
Min. capacity step		%	-	-	-	-	-
Refrigerant			R513A	R513A	R513A	R513A	R513A
Refrigerant charge		kg	197	210	220	237	260
Oil charge		kg	70,0	70,0	70,0	54,0	54,0
Rc (ASHRAE)	(3)	kg/kW	0,18	0,18	0,18	0,18	0,18
<b>FANS</b>							
Fans number		N°	18	18	20	20	20
Air flow		m³/s	86,43	86,43	96,03	96,03	96,03
Fans power input		kW	1,10	1,10	1,10	1,10	1,10
<b>NOISE LEVEL</b>							
Sound Pressure	(4)	dB(A)	63	63	63	63	63
Sound power level in cooling	(5)(6)	dB(A)	96	96	96	96	96
<b>SIZE AND WEIGHT</b>							
A	(7)	mm	11650	11650	12900	12900	12900
B	(7)	mm	2260	2260	2260	2260	2260
H	(7)	mm	2500	2500	2500	2500	2500
Operating weight	(7)	kg	9310	9640	10080	11410	11420

Notes:

- 1 Plant (side) cooling exchanger water (in/out) 12,00°C/7,00°C; Source (side) heat exchanger air (in) 35,0°C.
- 2 Values in compliance with EN14511
- 3 Rated in accordance with AHRI Standard 550/590 (2011 with addendum 1).
- 4 Average sound pressure level at 10m distance, unit in a free field on a reflective surface; non-binding value calculated from the sound power level.
- 5 Sound power on the basis of measurements made in compliance with ISO 9614.
- 6 Sound power level in cooling, outdoors.
- 7 Unit in standard configuration/execution, without optional accessories.

- Not available

Certified data in EUROVENT

GENERAL TECHNICAL DATA

ENERGY EFFICIENCY  
SEASONAL EFFICIENCY IN COOLING (Reg. EU 2016/2281)  
Process Refrigeration at high temperature

i-FR-G05-Z /K			2202	2602	2652	2702	2722	3152	3602	3902	4202	4502	4802
Prated,c	(1)	kW	477,3	529,4	559,6	596,2	654,7	718,2	798,9	871,3	928,7	987,3	1026
SEPR	(1) (2)	-	5,56	5,51	5,51	5,51	5,50	5,51	5,54	5,50	5,50	5,61	5,60
i-FR-G05-Z /K			4812	4822	5412	6002	6022	6303	6903	7203	7213	7223	
Prated,c	(1)	kW	1050	1124	1166	1238	1297	1405	1488	1555	1644	1691	
SEPR	(1) (2)	-	5,50	5,50	5,67	5,70	5,56	5,51	5,51	5,51	5,50	5,50	

i-FR-G05-Z /K /NR			2202	2602	2652	2702	2722	3152	3602	3902	4202	4502	4802
Prated,c	(1)	kW	473,0	525,2	554,9	591,7	649,4	712,6	785,6	857,3	914,5	970,6	1007
SEPR	(1) (2)	-	5,56	5,53	5,53	5,50	5,50	5,52	5,60	5,50	5,50	5,63	5,66
i-FR-G05-Z /K /NR			4812	4822	5412	6002	6022	6303	6903	7203	7213	7223	
Prated,c	(1)	kW	1042	1114	1155	1228	1286	1383	1462	1526	1615	1661	
SEPR	(1) (2)	-	5,50	5,50	5,69	5,72	5,58	5,50	5,50	5,53	5,50	5,50	

i-FR-G05-Z /SL-K			2202	2602	2652	2702	2722	3152	3602	3902	4202	4502	4802
Prated,c	(1)	kW	475,7	515,1	553,0	576,3	660,9	708,9	772,0	843,1	900,1	969,8	1025
SEPR	(1) (2)	-	5,73	5,68	5,68	5,50	5,52	5,60	5,63	5,50	5,50	5,66	5,64
i-FR-G05-Z /SL-K			4812	4822	5412	6002	6022	6303	6903	7203	7213	7223	
Prated,c	(1)	kW	1042	1116	1159	1195	1286	1361	1469	1537	1586	1630	
SEPR	(1) (2)	-	5,63	5,55	5,67	5,76	5,65	5,70	5,84	5,76	5,66	5,61	

i-FR-G05-Z /K /EC			2202	2602	2652	2702	2722	3152	3602	3902	4202	4502	4802
Prated,c	(1)	kW	477,3	529,4	559,6	596,2	654,7	718,2	798,9	871,3	928,7	987,3	1026
SEPR	(1) (2)	-	5,71	5,65	5,60	5,63	5,53	5,61	5,68	5,54	5,55	5,74	5,73
i-FR-G05-Z /K /EC			4812	4822	5412	6002	6022	6303	6903	7203	7213	7223	
Prated,c	(1)	kW	1050	1124	1166	1238	1297	1405	1488	1555	1644	1691	
SEPR	(1) (2)	-	5,62	5,53	5,80	5,84	5,69	5,54	5,58	5,63	5,53	5,54	

i-FR-G05-Z /K /NR + EC			2202	2602	2652	2702	2722	3152	3602	3902	4202	4502	4802
Prated,c	(1)	kW	473,0	525,2	554,9	591,7	649,4	712,6	785,6	857,3	914,5	970,6	1007
SEPR	(1) (2)	-	5,71	5,68	5,66	5,65	5,56	5,66	5,75	5,63	5,60	5,77	5,80
i-FR-G05-Z /K /NR + EC			4812	4822	5412	6002	6022	6303	6903	7203	7213	7223	
Prated,c	(1)	kW	1042	1114	1155	1228	1286	1383	1462	1526	1615	1661	
SEPR	(1) (2)	-	5,63	5,56	5,83	5,88	5,73	5,57	5,61	5,67	5,55	5,56	

Notes:  
(1) Seasonal energy efficiency of high temperature process cooling [REGULATION (EU) N. 2016/2281]  
(2) Seasonal process cooling energy index

Certified data in EUROVENT



GENERAL TECHNICAL DATA

SEASONAL EFFICIENCY IN COOLING (Reg. EU 2016/2281)  
Process Refrigeration at high temperature

i-FR-G05-Z /SL-K /EC			2202	2602	2652	2702	2722	3152	3602	3902	4202	4502	4802
Prated,c	(1)	kW	475,7	515,1	553,0	576,3	660,9	708,9	772,0	843,1	900,1	969,8	1025
SEPR	(1) (2)	-	5,91	5,86	5,85	5,66	5,70	5,77	5,79	5,65	5,61	5,82	5,81
i-FR-G05-Z /SL-K /EC			4812	4822	5412	6002	6022	6303	6903	7203	7213	7223	
Prated,c	(1)	kW	1042	1116	1159	1195	1286	1361	1469	1537	1586	1630	
SEPR	(1) (2)	-	5,82	5,72	5,84	5,93	5,82	5,87	6,02	5,93	5,82	5,77	

i-FR-G05-Z /A			2202	2602	2652	2702	2722	3152	3602	3902	4202	4502	4802
Prated,c	(1)	kW	508,7	550,4	588,2	624,8	682,1	765,0	837,1	896,4	955,9	1025	1095
SEPR	(1) (2)	-	5,98	5,89	5,87	5,92	5,77	5,87	5,88	5,67	5,60	5,73	5,80
i-FR-G05-Z /A			4822	5412	5703	6303	6603						
Prated,c	(1)	kW	1159	1226	1330	1463	1516						
SEPR	(1) (2)	-	5,75	5,71	5,71	5,64	5,61						

i-FR-G05-Z /A /NR			2202	2602	2652	2702	2722	3152	3602	3902	4202	4502	4802
Prated,c	(1)	kW	505,7	547,0	584,8	621,4	678,1	760,4	832,1	891,5	951,2	1019	1088
SEPR	(1) (2)	-	5,96	5,94	5,93	5,98	5,84	5,92	5,91	5,68	5,61	5,75	5,84
i-FR-G05-Z /A /NR			4822	5412	5703	6303	6603						
Prated,c	(1)	kW	1152	1218	1322	1455	1507						
SEPR	(1) (2)	-	5,77	5,73	5,71	5,65	5,64						

i-FR-G05-Z /SL-A			2202	2602	2652	2702	2722	3152	3602	3902	4202	4502	4802
Prated,c	(1)	kW	497,4	557,9	580,0	613,4	680,6	749,5	809,4	888,6	939,4	1013	1082
SEPR	(1) (2)	-	6,10	5,98	5,93	5,94	5,80	5,92	5,98	5,90	5,85	5,96	5,90
i-FR-G05-Z /SL-A			4822	5412	5703	6303							
Prated,c	(1)	kW	1146	1209	1328	1458							
SEPR	(1) (2)	-	5,83	5,89	5,98	5,93							

Notes:

(1) Seasonal energy efficiency of high temperature process cooling [REGULATION (EU) N. 2016/2281]

(2) Seasonal process cooling energy index

Certified data in EUROVENT







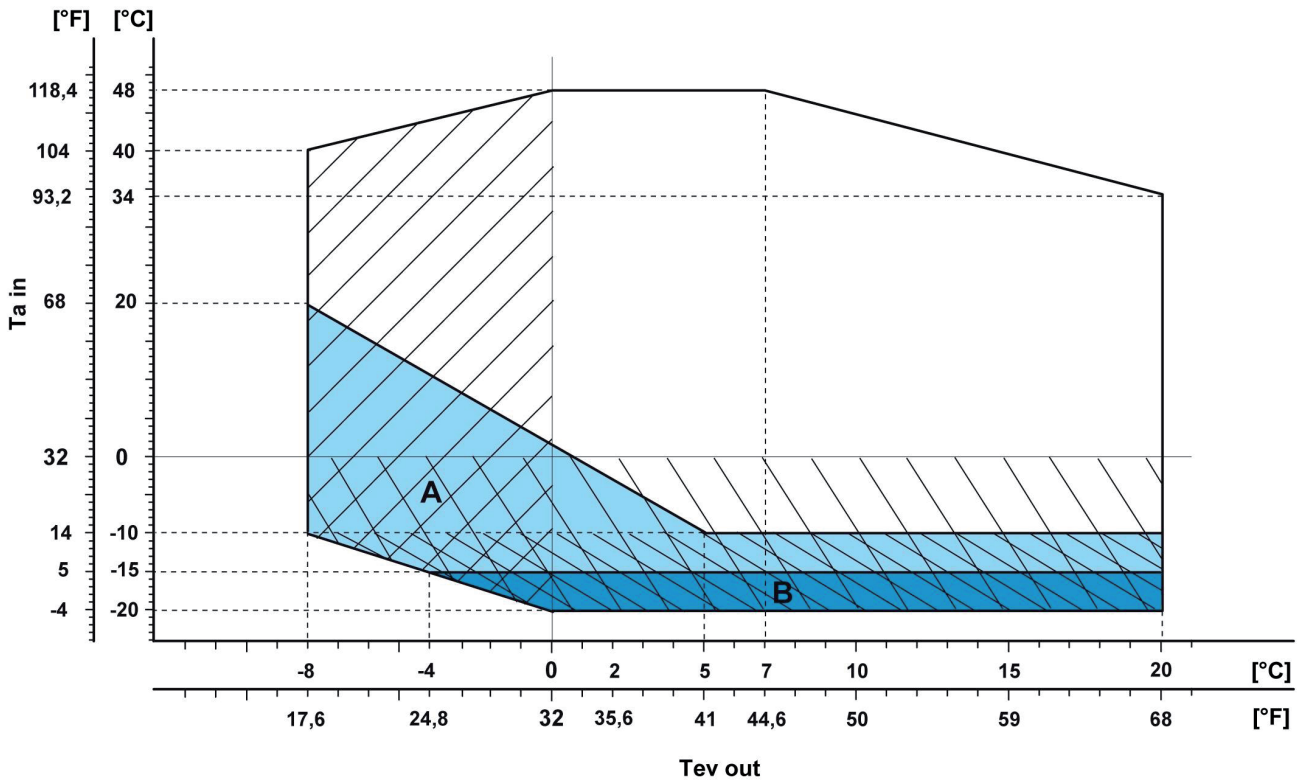



/K  
/SL-K



**Ta in** Air temperature  
**Tev out** Evaporator leaving water temperature

The diagram shows the temperature limits of full load operation. In case of higher outdoor air temperature, automatically partialized its resources to ensure uninterrupted operation. Operating limits when working partialized (water  $\approx 7^\circ\text{C} - \approx 44,6^\circ\text{F}$ ): /K, /SL-K:  $53^\circ\text{C} - 131^\circ\text{F}$

-  Standard units
-  Required: EC fans (code 808)\*
-  Required: EC fans (code 808)\*  
Low temperature device DBA (code 813)
-  Required: Antifreeze piping and pumps (code 2432) if hydronic kit is present
-  Required: Double insulaiton on heat exchangers (code 2631) or Double insulation on heat exchangers, pipes and pumps (code 2633) if hydronic kit is present
-  Required: Negative fluid temperature (code 871)

Units with heat recovery: /D, /R  
 For the units with heat recovery, the maximum outdoor temperature allowed are  $1,5^\circ\text{C} - 2,7^\circ\text{F}$  lower than the ones of the corresponding model without heat recovery.

\* EC fans are suitable to operate up to  $46^\circ\text{C} - 114,8^\circ\text{F}$  of outdoor temperature. In case of higher temperatures, fans with oversized motors must be used. For the quotation of these components, please contact our sales department.

For the specific temperature limits of each model please refer to the selection software ElcaStudio.

SIZE				
i-FR-G05-Z /K /2202	i-FR-G05-Z /K /2702	i-FR-G05-Z /K /3602	i-FR-G05-Z /K /4502	i-FR-G05-Z /K /4822
i-FR-G05-Z /K /2602	i-FR-G05-Z /K /2722	i-FR-G05-Z /K /3902	i-FR-G05-Z /K /4802	i-FR-G05-Z /K /5412
i-FR-G05-Z /K /2652	i-FR-G05-Z /K /3152	i-FR-G05-Z /K /4202	i-FR-G05-Z /K /4812	i-FR-G05-Z /K /6002

**OPERATING LIMITS**





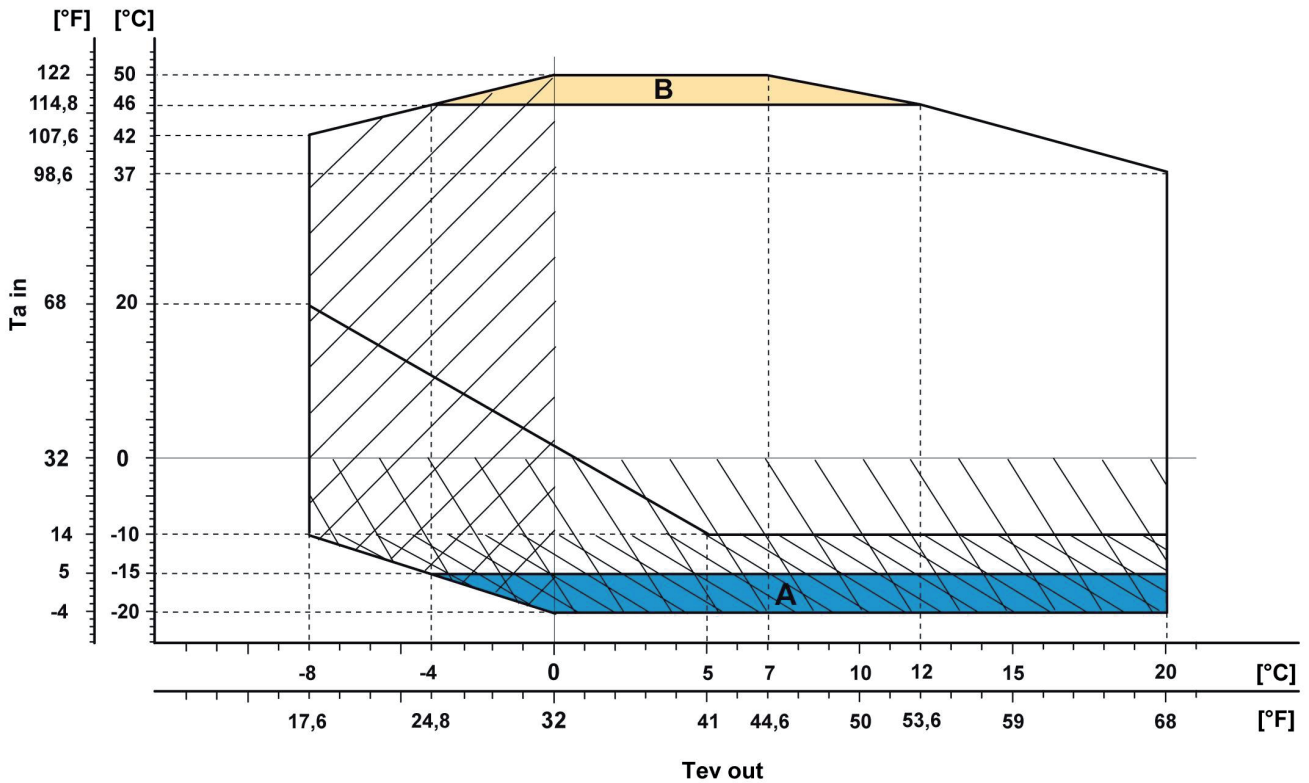

i-FR-G05-Z 2202 - 7223

SIZE
i-FR-G05-Z /K /6022
i-FR-G05-Z /K /6303
i-FR-G05-Z /K /6903
i-FR-G05-Z /K /7203
i-FR-G05-Z /K /7213
i-FR-G05-Z /K /7223
i-FR-G05-Z /SL-K /2202
i-FR-G05-Z /SL-K /2602
i-FR-G05-Z /SL-K /2652
i-FR-G05-Z /SL-K /2702
i-FR-G05-Z /SL-K /2722
i-FR-G05-Z /SL-K /3152
i-FR-G05-Z /SL-K /3602
i-FR-G05-Z /SL-K /3902
i-FR-G05-Z /SL-K /4202
i-FR-G05-Z /SL-K /4502
i-FR-G05-Z /SL-K /4802
i-FR-G05-Z /SL-K /4812
i-FR-G05-Z /SL-K /4822
i-FR-G05-Z /SL-K /5412
i-FR-G05-Z /SL-K /6002
i-FR-G05-Z /SL-K /6022
i-FR-G05-Z /SL-K /6303
i-FR-G05-Z /SL-K /6903
i-FR-G05-Z /SL-K /7203
i-FR-G05-Z /SL-K /7213
i-FR-G05-Z /SL-K /7223

/A  
/SL-A



**Ta in** Air temperature  
**Tev out** Evaporator leaving water temperature

-  Standard units
-  Required: Low temperature device DBA (code 813)
-  Required: Kit HT (code 1955)
-  Required: Antifreeze piping and pumps (code 2432) if hydronic kit is present
-  Required: Double insultaion on heat exchangers (code 2631) or Double insulation on heat exchangers, pipes and pumps (code 2633) if hydronic kit is present
-  Required: Negative fluid temperature (code 871)

The diagram shows the temperature limits of full load operation. In case of higher outdoor air temperature, automatically partialized its resources to ensure uninterrupted operation. Operating limits when working partialized with Kit HT (code 1955) (water \*7°C - \*/44,6°F): /A , /SL-A : 55°C - 131°F With Kit HT (all versions): 57°C - 134,6°F

In case of outdoor air temperature higher than 53°C - 127,4°F, some additional cooling equipment for the electrical panel could be necessary. Please refer to our sales department for assessment and quotation.

Units with heat recovery: /D, /R  
 For the units with heat recovery, the maximum outdoor temperature allowed are 1,5°C - 2,7°F lower than the ones of the corresponding model without heat recovery.

For the specific temperature limits of each model please refer to the selection software ElcaStudio.

SIZE				
i-FR-G05-Z /A /2202	i-FR-G05-Z /A /2702	i-FR-G05-Z /A /3602	i-FR-G05-Z /A /4502	i-FR-G05-Z /A /5412
i-FR-G05-Z /A /2602	i-FR-G05-Z /A /2722	i-FR-G05-Z /A /3902	i-FR-G05-Z /A /4802	i-FR-G05-Z /A /5703
i-FR-G05-Z /A /2652	i-FR-G05-Z /A /3152	i-FR-G05-Z /A /4202	i-FR-G05-Z /A /4822	i-FR-G05-Z /A /6303

SIZE
i-FR-G05-Z /A /6603
i-FR-G05-Z /SL-A /2202
i-FR-G05-Z /SL-A /2602
i-FR-G05-Z /SL-A /2652
i-FR-G05-Z /SL-A /2702
i-FR-G05-Z /SL-A /2722
i-FR-G05-Z /SL-A /3152
i-FR-G05-Z /SL-A /3602
i-FR-G05-Z /SL-A /3902
i-FR-G05-Z /SL-A /4202
i-FR-G05-Z /SL-A /4502
i-FR-G05-Z /SL-A /4802
i-FR-G05-Z /SL-A /4822
i-FR-G05-Z /SL-A /5412
i-FR-G05-Z /SL-A /5703
i-FR-G05-Z /SL-A /6303

**5.2 ETHYLENE GLYCOL MIXTURE**

Ethylene glycol and water mixture, used as a heat-conveying fluid, cause a variation in unit performance. For correct data, use the factors indicated in the following table.

	Freezing point (°C)							
	0	-5	-10	-15	-20	-25	-30	-35
	Ethylene glycol percentage by weight							
	0%	12%	20%	30%	35%	40%	45%	50%
cPf	1	0,985	0,98	0,974	0,97	0,965	0,964	0,96
cQ	1	1,02	1,04	1,075	1,11	1,14	1,17	1,2
cdp	1	1,07	1,11	1,18	1,22	1,24	1,27	1,3

cPf: cooling power correction factor  
 cQ: flow correction factor  
 cdp: pressure drop correction factor

For data concerning other kind of anti-freeze solutions (e.g. propylene glycol) please contact our Sale Department.

**5.3 FOULING FACTORS**

Performances are based on clean condition of tubes (fouling factor = 1). For different fouling values, performance should be adjusted using the correction factors shown in the following table.

SERIES	FOULING FACTORS	EVAPORATOR			CONDENSER/RECOVERY			DESUPERHEATER
	ff (m <sup>2</sup> °CW)	F1	FK1	KE [°C]	F2	FK2	KC [°C]	R3
VARIOUS	0	1,000	1,000	0,0	1,000	1,000	0,0	1,000
VARIOUS	1,80 x 10 <sup>-5</sup>	1,000	1,000	0,0	1,000	1,000	0,0	1,000
VARIOUS	4,40 x 10 <sup>-5</sup>	1,000	1,000	0,0	0,990	1,030	1,0	0,990
VARIOUS	8,80 x 10 <sup>-5</sup>	0,960	0,990	0,7	0,980	1,040	1,5	0,980
VARIOUS	13,20 x 10 <sup>-5</sup>	0,944	0,985	1,0	0,964	1,050	2,3	0,964
VARIOUS	17,20 x 10 <sup>-5</sup>	0,930	0,980	1,5	0,950	1,060	3,0	0,950

ff: fouling factors  
 F1 - F2: potential correction factors  
 FK1 - FK2: compressor power input correction factors  
 R3: capacity correction factors  
 KE: minimum evaporator outlet temperature increase  
 KC: maximum condenser outlet temperature decrease

## OPERATING LIMITS

### OPERATION LIMITS OF DE-SUPERHEATERS

If it isn't possible to guarantee the indicated minimum temperatures, it is wise to install a dedicated kit for protection of de-superheater (device subject to RFQ - request feasibility and quotation) (see figure).

De-superheater minimum inlet temperature = 25°C

De-superheater minimum outlet temperature = 30°C

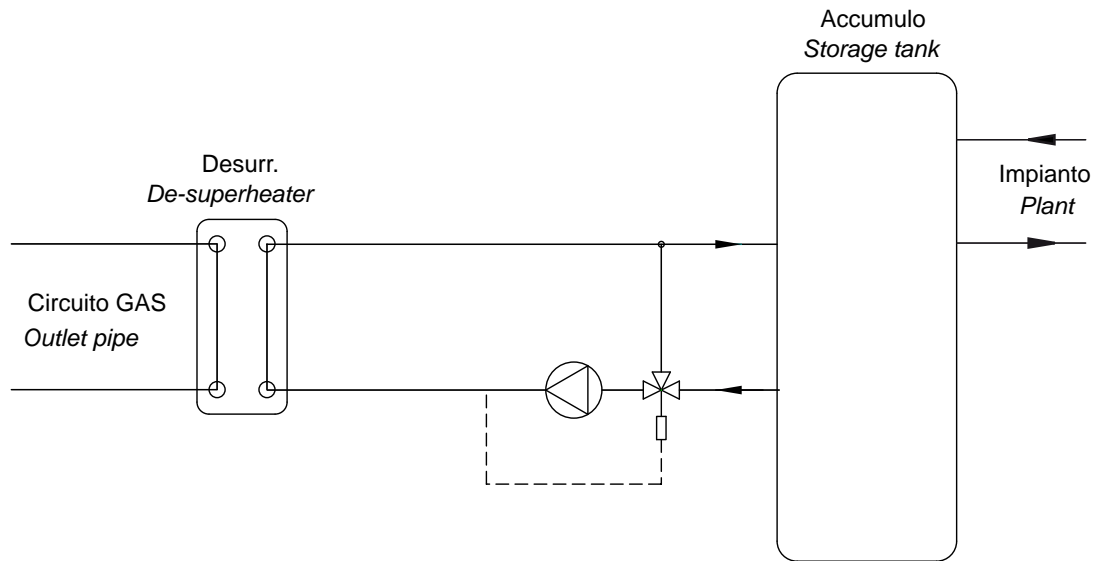

## 6.1 HYDRAULIC DATA

[ SI System ]

### Water flow and pressure drop

Water flow in the plant (side) exchanger is given by:

$$Q = P / (4,186 \times \Delta t)$$

Q: water flow (l/s)

$\Delta t$ : difference between inlet and outlet water temp. (°C)

P: heat exchanger capacity (kW)

Pressure drop is given by:

$$\Delta p = K \times (3,6 \times Q)^2 / 1000$$

Q: water flow (l/s)

$\Delta p$ : pressure drop (kPa)

K: unit size ratio

SIZE	Power supply V/ph/Hz	HEAT EXCHANGER USER SIDE				
		K	Q min l/s	Q max l/s	C.A.S. l	C.a. min l
i-FR-G05-Z /K /2202	400/3/50	4,72	12,50	40,00	140	1700
i-FR-G05-Z /K /2602	400/3/50	4,72	12,50	40,00	140	1900
i-FR-G05-Z /K /2652	400/3/50	3,77	15,83	46,94	124	2000
i-FR-G05-Z /K /2702	400/3/50	3,77	15,83	46,94	124	2100
i-FR-G05-Z /K /2722	400/3/50	3,00	17,50	50,28	230	2300
i-FR-G05-Z /K /3152	400/3/50	3,00	17,50	50,28	230	2500
i-FR-G05-Z /K /3602	400/3/50	2,14	19,17	54,44	220	2800
i-FR-G05-Z /K /3902	400/3/50	1,89	19,17	56,11	210	3100
i-FR-G05-Z /K /4202	400/3/50	1,89	19,17	56,11	210	3300
i-FR-G05-Z /K /4502	400/3/50	1,46	25,00	63,89	275	3500
i-FR-G05-Z /K /4802	400/3/50	1,46	25,00	63,89	275	3600
i-FR-G05-Z /K /4812	400/3/50	1,46	25,00	63,89	275	3700
i-FR-G05-Z /K /4822	400/3/50	1,37	25,00	68,89	261	3900
i-FR-G05-Z /K /5412	400/3/50	1,03	31,11	100,8	310	4100
i-FR-G05-Z /K /6002	400/3/50	1,03	31,11	100,8	310	4300
i-FR-G05-Z /K /6022	400/3/50	1,03	31,11	100,8	310	4600
i-FR-G05-Z /K /6303	400/3/50	0,78	41,67	102,8	575	4900
i-FR-G05-Z /K /6903	400/3/50	0,78	41,67	102,8	575	5200
i-FR-G05-Z /K /7203	400/3/50	0,55	41,67	97,22	550	5500
i-FR-G05-Z /K /7213	400/3/50	0,55	41,67	97,22	550	5800
i-FR-G05-Z /K /7223	400/3/50	0,59	41,67	100,0	500	5900
i-FR-G05-Z /SL-K /2202	400/3/50	4,72	12,50	40,00	140	1700
i-FR-G05-Z /SL-K /2602	400/3/50	4,72	12,50	40,00	140	1900
i-FR-G05-Z /SL-K /2652	400/3/50	3,77	15,83	46,94	124	2000
i-FR-G05-Z /SL-K /2702	400/3/50	3,77	15,83	46,94	124	2100
i-FR-G05-Z /SL-K /2722	400/3/50	3,00	17,50	50,28	230	2300
i-FR-G05-Z /SL-K /3152	400/3/50	3,00	17,50	50,28	230	2500
i-FR-G05-Z /SL-K /3602	400/3/50	2,14	19,17	54,44	220	2800
i-FR-G05-Z /SL-K /3902	400/3/50	1,89	19,17	56,11	210	3100
i-FR-G05-Z /SL-K /4202	400/3/50	1,89	19,17	56,11	210	3300
i-FR-G05-Z /SL-K /4502	400/3/50	1,46	25,00	63,89	275	3500
i-FR-G05-Z /SL-K /4802	400/3/50	1,46	25,00	63,89	275	3600
i-FR-G05-Z /SL-K /4812	400/3/50	1,46	25,00	63,89	275	3700
i-FR-G05-Z /SL-K /4822	400/3/50	1,37	25,00	68,89	261	3900
i-FR-G05-Z /SL-K /5412	400/3/50	1,03	31,11	100,8	310	4100
i-FR-G05-Z /SL-K /6002	400/3/50	1,03	31,11	100,8	310	4300
i-FR-G05-Z /SL-K /6022	400/3/50	1,03	31,11	100,8	310	4600
i-FR-G05-Z /SL-K /6303	400/3/50	0,78	41,67	102,8	575	4900
i-FR-G05-Z /SL-K /6903	400/3/50	0,78	41,67	102,8	575	5200
i-FR-G05-Z /SL-K /7203	400/3/50	0,55	41,67	97,22	550	5500
i-FR-G05-Z /SL-K /7213	400/3/50	0,55	41,67	97,22	550	5800
i-FR-G05-Z /SL-K /7223	400/3/50	0,59	41,67	100,0	500	5900

Q min: minimum water flow admitted to the heat exchanger

Q max: maximum water flow admitted to the heat exchanger

C.a. min: minimum water content admitted in the plant

C.A.S.: Exchanger water content

## HYDRAULIC DATA

[ SI System ]

SIZE	Power supply V/ph/Hz	HEAT EXCHANGER USER SIDE				
		K	Q min l/s	Q max l/s	C.A.S. l	C.a. min l
i-FR-G05-Z /A /2202	400/3/50	4,72	12,50	40,00	140	1800
i-FR-G05-Z /A /2602	400/3/50	3,77	15,83	46,94	124	1900
i-FR-G05-Z /A /2652	400/3/50	3,77	15,83	46,94	124	2100
i-FR-G05-Z /A /2702	400/3/50	3,77	15,83	46,94	124	2200
i-FR-G05-Z /A /2722	400/3/50	3,00	17,50	50,28	230	2400
i-FR-G05-Z /A /3152	400/3/50	2,14	19,17	54,44	220	2700
i-FR-G05-Z /A /3602	400/3/50	2,14	19,17	54,44	220	2900
i-FR-G05-Z /A /3902	400/3/50	1,89	19,17	56,11	210	3100
i-FR-G05-Z /A /4202	400/3/50	1,89	19,17	56,11	210	3400
i-FR-G05-Z /A /4502	400/3/50	1,46	25,00	63,89	275	3600
i-FR-G05-Z /A /4802	400/3/50	1,40	25,00	66,94	269	3800
i-FR-G05-Z /A /4822	400/3/50	1,03	31,11	100,8	310	4100
i-FR-G05-Z /A /5412	400/3/50	1,03	31,11	100,8	310	4300
i-FR-G05-Z /A /5703	400/3/50	0,78	41,67	102,8	575	4700
i-FR-G05-Z /A /6303	400/3/50	0,55	41,67	97,22	550	5100
i-FR-G05-Z /A /6603	400/3/50	0,55	50,00	100,0	500	5300
i-FR-G05-Z /SL-A /2202	400/3/50	4,72	12,50	40,00	140	1800
i-FR-G05-Z /SL-A /2602	400/3/50	3,77	15,83	46,94	124	1900
i-FR-G05-Z /SL-A /2652	400/3/50	3,77	15,83	46,94	124	2100
i-FR-G05-Z /SL-A /2702	400/3/50	3,00	17,50	50,28	230	2200
i-FR-G05-Z /SL-A /2722	400/3/50	3,00	17,50	50,28	230	2400
i-FR-G05-Z /SL-A /3152	400/3/50	2,14	19,17	54,44	220	2700
i-FR-G05-Z /SL-A /3602	400/3/50	2,14	19,17	54,44	220	2900
i-FR-G05-Z /SL-A /3902	400/3/50	1,89	19,17	56,11	210	3100
i-FR-G05-Z /SL-A /4202	400/3/50	1,89	19,17	56,11	210	3400
i-FR-G05-Z /SL-A /4502	400/3/50	1,46	25,00	63,89	275	3600
i-FR-G05-Z /SL-A /4802	400/3/50	1,40	25,00	66,94	269	3800
i-FR-G05-Z /SL-A /4822	400/3/50	1,03	31,11	100,8	310	4100
i-FR-G05-Z /SL-A /5412	400/3/50	1,03	31,11	100,8	310	4300
i-FR-G05-Z /SL-A /5703	400/3/50	0,78	41,67	102,8	575	4700
i-FR-G05-Z /SL-A /6303	400/3/50	0,55	50,00	97,22	550	5100

Q min: minimum water flow admitted to the heat exchanger  
 Q max: maximum water flow admitted to the heat exchanger  
 C.a. min: minimum water content admitted in the plant  
 C.A.S.: Exchanger water content

## 7.1 ELECTRICAL DATA

## i-FR-G05-Z/K

[ SI System ]

SIZE	Power supply V/ph/Hz	Maximum values								
		n	Compressor			Fans (1)		Total (1)(2)		
			F.L.I. [kW]	F.L.A. [A]	L.R.A. [A]	F.L.I. [kW]	F.L.A. [A]	F.L.I. [kW]	F.L.A. [A]	S.A. [A]
2202	400/3/50	2	2 x 99	2 x 163	2 x 20	2,000	4	210,0	349	0
2602	400/3/50	2	1 x 123 + 1 x 99	1 x 200 + 1 x 163	2 x 20	2,000	4	236,0	390	0
2652	400/3/50	2	1 x 125 + 1 x 106	1 x 202 + 1 x 174	2 x 20	2,000	4	245,0	403	0
2702	400/3/50	2	2 x 123	2 x 200	2 x 20	2,000	4	262,0	430	0
2722	400/3/50	2	2 x 137	2 x 220	2 x 20	2,000	4	290,0	470	0
3152	400/3/50	2	1 x 176 + 1 x 137	1 x 280 + 1 x 220	2 x 20	2,000	4	331,0	534	0
3602	400/3/50	2	2 x 176	2 x 280	2 x 20	2,000	4	372,0	598	0
3902	400/3/50	2	1 x 188 + 1 x 176	1 x 298 + 1 x 280	2 x 20	2,000	4	386,0	620	0
4202	400/3/50	2	2 x 188	2 x 298	2 x 20	2,000	4	400,0	642	0
4502	400/3/50	2	1 x 222 + 1 x 188	1 x 357 + 1 x 298	2 x 20	2,000	4	434,0	701	0
4802	400/3/50	2	2 x 222	2 x 357	2 x 20	2,000	4	468,0	760	0
4812	400/3/50	2	2 x 222	2 x 357	2 x 20	2,000	4	472,0	767	0
4822	400/3/50	2	2 x 236	2 x 378	2 x 20	2,000	4	500,0	809	0
5412	400/3/50	2	1 x 267 + 1 x 236	1 x 428 + 1 x 378	2 x 20	2,000	4	531,0	859	0
6002	400/3/50	2	2 x 267	2 x 428	2 x 20	2,000	4	566,0	917	0
6022	400/3/50	2	2 x 281	2 x 451	2 x 20	2,000	4	594,0	963	0
6303	400/3/50	3	3 x 188	3 x 298	3 x 20	2,000	4	600,0	962	0
6903	400/3/50	2	2 x 222 + 1 x 188	2 x 357 + 1 x 298	3 x 20	2,000	4	668,0	1080	0
7203	400/3/50	3	3 x 222	3 x 357	3 x 20	2,000	4	702,0	1139	0
7213	400/3/50	3	2 x 236 + 1 x 222	2 x 378 + 1 x 357	3 x 20	2,000	4	734,0	1189	0
7223	400/3/50	3	3 x 236	3 x 378	3 x 20	2,000	4	748,0	1210	0

**F.L.I.:** Full load power

**F.L.A.:** Full load current

**L.R.A.:** Locked rotor amperes for single compressor

**S.A.:** Inrush current

(1) Values calculated referring to the version with the maximum number of fans working at the max absorbed current

(1)(2) Safety values to be considered when cabling the unit for power supply and line-protections

Data valid for standard units without any additional option.

Plant (side) cooling exchanger water (in/out) 12,00°C/7,00°C; Source (side) heat exchanger air (in) 35,0°C.

Voltage tolerance: 10%

Maximum voltage unbalance: 3%

Give the typical operating conditions of units designed for outdoor installation, which can be associated (according to reference document IEC 60721) to the following classes:

- climatic conditions class 4K4H: air temperature range from -20 up to 55°C (\*), relative humidity range from 4 up to 100%, with possible precipitations, at air pressure from 70 and 106 kPa and a maximum solar radiation of 1120 W/m<sup>2</sup>

- special climatic conditions negligible

- biological conditions class 4B1 and 4C2: locations in a generic urban area

- mechanically active substances class 4S2: locations in areas with sand or dust representative of urban areas

- mechanical conditions class 4M1: locations protected from significant vibrations or shocks

The required protection level for safe operation, according to reference document IEC 60529, is IP43XW (protection against access, to the most critical unit's parts, of external devices with diameter larger than 1 mm and rain).

The unit can be considered IP44XW protected, i.e. protected against access of external devices (with diameter larger than 1 mm) and water in general.

(\*) for the unit's operating limits, see "selection limits" section



**ELECTRICAL DATA**

**i-FR-G05-Z/SL-K**

[ SI System ]

SIZE	Power supply V/ph/Hz	Maximum values								
		n	Compressor			Fans (1)		Total (1)(2)		
			F.L.I. [kW]	F.L.A. [A]	L.R.A. [A]	F.L.I. [kW]	F.L.A. [A]	F.L.I. [kW]	F.L.A. [A]	S.A. [A]
2202	400/3/50	2	1 x 107 + 1 x 92	1 x 176 + 1 x 152	2 x 20	2,000	4	213,0	355	0
2602	400/3/50	2	2 x 135	2 x 218	2 x 20	2,000	4	286,0	466	0
2652	400/3/50	2	1 x 123 + 1 x 106	1 x 200 + 1 x 174	2 x 20	2,000	4	245,0	404	0
2702	400/3/50	2	2 x 123	2 x 200	2 x 20	2,000	4	262,0	430	0
2722	400/3/50	2	2 x 137	2 x 220	2 x 20	2,000	4	294,0	478	0
3152	400/3/50	2	1 x 176 + 1 x 137	1 x 280 + 1 x 220	2 x 20	2,000	4	333,0	538	0
3602	400/3/50	2	2 x 176	2 x 280	2 x 20	2,000	4	372,0	598	0
3902	400/3/50	2	1 x 188 + 1 x 176	1 x 298 + 1 x 280	2 x 20	2,000	4	386,0	620	0
4202	400/3/50	2	2 x 188	2 x 298	2 x 20	2,000	4	400,0	642	0
4502	400/3/50	2	1 x 222 + 1 x 188	1 x 357 + 1 x 298	2 x 20	2,000	4	434,0	701	0
4802	400/3/50	2	2 x 222	2 x 357	2 x 20	2,000	4	468,0	760	0
4812	400/3/50	2	2 x 222	2 x 357	2 x 20	2,000	4	472,0	767	0
4822	400/3/50	2	2 x 236	2 x 378	2 x 20	2,000	4	500,0	809	0
5412	400/3/50	2	1 x 267 + 1 x 236	1 x 428 + 1 x 378	2 x 20	2,000	4	531,0	859	0
6002	400/3/50	2	2 x 267	2 x 428	2 x 20	2,000	4	566,0	917	0
6022	400/3/50	2	2 x 281	2 x 451	2 x 20	2,000	4	594,0	963	0
6303	400/3/50	3	3 x 188	3 x 298	3 x 20	2,000	4	600,0	962	0
6903	400/3/50	2	2 x 222 + 1 x 188	2 x 357 + 1 x 298	3 x 20	2,000	4	668,0	1080	0
7203	400/3/50	3	3 x 222	3 x 357	3 x 20	2,000	4	702,0	1139	0
7213	400/3/50	2	2 x 236 + 1 x 222	2 x 378 + 1 x 357	3 x 20	2,000	4	734,0	1189	0
7223	400/3/50	3	3 x 236	3 x 378	3 x 20	2,000	4	748,0	1210	0

**F.L.I.:** Full load power

**F.L.A.:** Full load current

**L.R.A.:** Locked rotor amperes for single compressor

**S.A.:** Inrush current

(1) Values calculated referring to the version with the maximum number of fans working at the max absorbed current

(1)(2) Safety values to be considered when cabling the unit for power supply and line-protections

Data valid for standard units without any additional option.

Plant (side) cooling exchanger water (in/out) 12,00°C/7,00°C; Source (side) heat exchanger air (in) 35,0°C.

Voltage tolerance: 10%

Maximum voltage unbalance: 3%

Give the typical operating conditions of units designed for outdoor installation, which can be associated (according to reference document IEC 60721) to the following classes:

- climatic conditions class 4K4H: air temperature range from -20 up to 55°C (\*), relative humidity range from 4 up to 100%, with possible precipitations, at air pressure from 70 and 106 kPa and a maximum solar radiation of 1120 W/m2

- special climatic conditions negligible

- biological conditions class 4B1 and 4C2: locations in a generic urban area

- mechanically active substances class 4S2: locations in areas with sand or dust representative of urban areas

- mechanical conditions class 4M1: locations protected from significant vibrations or shocks

The required protection level for safe operation, according to reference document IEC 60529, is IP43XW (protection against access, to the most critical unit's parts, of external devices with diameter larger than 1 mm and rain).

The unit can be considered IP44XW protected, i.e. protected against access of external devices (with diameter larger than 1 mm) and water in general.

(\*) for the unit's operating limits, see "selection limits" section

**ELECTRICAL DATA**

**i-FR-G05-Z/A**

[ SI System ]

SIZE	Power supply V/ph/Hz	Maximum values								
		n	Compressor			Fans (1)		Total (1)(2)		
			F.L.I. [kW]	F.L.A. [A]	L.R.A. [A]	F.L.I. [kW]	F.L.A. [A]	F.L.I. [kW]	F.L.A. [A]	S.A. [A]
2202	400/3/50	2	2 x 100	2 x 164	2 x 20	1,950	3	216,0	354	0
2602	400/3/50	2	2 x 107	2 x 176	2 x 20	1,950	3	230,0	378	0
2652	400/3/50	2	1 x 125 + 1 x 107	1 x 202 + 1 x 176	2 x 20	1,950	3	250,0	408	0
2702	400/3/50	2	2 x 125	2 x 202	2 x 20	1,950	3	270,0	437	0
2722	400/3/50	2	2 x 137	2 x 220	2 x 20	1,950	3	294,0	473	0
3152	400/3/50	2	1 x 181 + 1 x 137	1 x 287 + 1 x 220	2 x 20	1,950	3	339,0	543	0
3602	400/3/50	2	2 x 181	2 x 287	2 x 20	1,950	3	385,0	614	0
3902	400/3/50	2	1 x 190 + 1 x 181	1 x 301 + 1 x 287	2 x 20	1,950	3	396,0	631	0
4202	400/3/50	2	2 x 190	2 x 301	2 x 20	1,950	3	407,0	648	0
4502	400/3/50	2	1 x 224 + 1 x 190	1 x 360 + 1 x 301	2 x 20	1,950	3	443,0	711	0
4802	400/3/50	2	2 x 224	2 x 360	2 x 20	1,950	3	479,0	773	0
4822	400/3/50	2	2 x 236	2 x 378	2 x 20	1,950	3	503,0	809	0
5412	400/3/50	2	1 x 267 + 1 x 236	1 x 428 + 1 x 378	2 x 20	1,950	3	538,0	865	0
5703	400/3/50	4	1 x 190 + 2 x 181	1 x 301 + 2 x 287	3 x 20	1,950	3	589,0	938	0
6303	400/3/50	3	3 x 190	3 x 301	3 x 20	1,950	3	609,0	969	0
6603	400/3/50	4	1 x 224 + 2 x 190	1 x 360 + 2 x 301	3 x 20	1,950	3	643,0	1028	0

F.L.I.: Full load power

F.L.A.: Full load current

L.R.A.: Locked rotor amperes for single compressor

S.A.: Inrush current

(1) Values calculated referring to the version with the maximum number of fans working at the max absorbed current

(1)(2) Safety values to be considered when cabling the unit for power supply and line-protections

Data valid for standard units without any additional option.

Plant (side) cooling exchanger water (in/out) 12,00°C/7,00°C; Source (side) heat exchanger air (in) 35,0°C.

Voltage tolerance: 10%

Maximum voltage unbalance: 3%

Give the typical operating conditions of units designed for outdoor installation, which can be associated (according to reference document IEC 60721) to the following classes:

- climatic conditions class 4K4H: air temperature range from -20 up to 55°C (\*), relative humidity range from 4 up to 100%, with possible precipitations, at air pressure from 70 and 106 kPa and a maximum solar radiation of 1120 W/m2

- special climatic conditions negligible

- biological conditions class 4B1 and 4C2: locations in a generic urban area

- mechanically active substances class 4S2: locations in areas with sand or dust representative of urban areas

- mechanical conditions class 4M1: locations protected from significant vibrations or shocks

The required protection level for safe operation, according to reference document IEC 60529, is IP43XW (protection against access, to the most critical unit's parts, of external devices with diameter larger than 1 mm and rain).

The unit can be considered IP44XW protected, i.e. protected against access of external devices (with diameter larger than 1 mm) and water in general.

(\*) for the unit's operating limits, see "selection limits" section

**ELECTRICAL DATA**

**i-FR-G05-Z/SL-A**

[ SI System ]

SIZE	Power supply V/ph/Hz	Maximum values								
		n	Compressor			Fans (1)		Total (1)(2)		
			F.L.I. [kW]	F.L.A. [A]	L.R.A. [A]	F.L.I. [kW]	F.L.A. [A]	F.L.I. [kW]	F.L.A. [A]	S.A. [A]
2202	400/3/50	2	2 x 100	2 x 164	2 x 20	1,950	3	216,0	354	0
2602	400/3/50	2	1 x 125 + 1 x 100	1 x 202 + 1 x 164	2 x 20	1,950	3	243,0	396	0
2652	400/3/50	2	1 x 125 + 1 x 107	1 x 202 + 1 x 176	2 x 20	1,950	3	252,0	411	0
2702	400/3/50	2	2 x 125	2 x 202	2 x 20	1,950	3	270,0	437	0
2722	400/3/50	2	2 x 137	2 x 220	2 x 20	1,950	3	297,0	480	0
3152	400/3/50	2	1 x 181 + 1 x 137	1 x 287 + 1 x 220	2 x 20	1,950	3	341,0	547	0
3602	400/3/50	2	2 x 181	2 x 287	2 x 20	1,950	3	389,0	620	0
3902	400/3/50	2	1 x 190 + 1 x 181	1 x 301 + 1 x 287	2 x 20	1,950	3	400,0	638	0
4202	400/3/50	2	2 x 190	2 x 301	2 x 20	1,950	3	411,0	655	0
4502	400/3/50	2	1 x 224 + 1 x 190	1 x 360 + 1 x 301	2 x 20	1,950	3	447,0	717	0
4802	400/3/50	2	2 x 224	2 x 360	2 x 20	1,950	3	483,0	779	0
4822	400/3/50	2	2 x 236	2 x 378	2 x 20	1,950	3	507,0	815	0
5412	400/3/50	2	1 x 267 + 1 x 236	1 x 428 + 1 x 378	2 x 20	1,950	3	542,0	872	0
5703	400/3/50	4	1 x 190 + 2 x 181	1 x 301 + 2 x 287	3 x 20	1,950	3	591,0	941	0
6303	400/3/50	3	3 x 190	3 x 301	3 x 20	1,950	3	609,0	969	0

F.L.I.: Full load power

F.L.A.: Full load current

L.R.A.: Locked rotor amperes for single compressor

S.A.: Inrush current

(1) Values calculated referring to the version with the maximum number of fans working at the max absorbed current

(1)(2) Safety values to be considered when cabling the unit for power supply and line-protections

Data valid for standard units without any additional option.

Plant (side) cooling exchanger water (in/out) 12,00°C/7,00°C; Source (side) heat exchanger air (in) 35,0°C.

Voltage tolerance: 10%

Maximum voltage unbalance: 3%

Give the typical operating conditions of units designed for outdoor installation, which can be associated (according to reference document IEC 60721) to the following classes:

- climatic conditions class 4K4H: air temperature range from -20 up to 55°C (\*), relative humidity range from 4 up to 100%, with possible precipitations, at air pressure from 70 and 106 kPa and a maximum solar radiation of 1120 W/m2

- special climatic conditions negligible

- biological conditions class 4B1 and 4C2: locations in a generic urban area

- mechanically active substances class 4S2: locations in areas with sand or dust representative of urban areas

- mechanical conditions class 4M1: locations protected from significant vibrations or shocks

The required protection level for safe operation, according to reference document IEC 60529, is IP43XW (protection against access, to the most critical unit's parts, of external devices with diameter larger than 1 mm and rain).

The unit can be considered IP44XW protected, i.e. protected against access of external devices (with diameter larger than 1 mm) and water in general.

(\*) for the unit's operating limits, see "selection limits" section

## ELECTRICAL DATA

### MAXIMUM CABLES/BARS SECTION CONNECTED TO MAIN SWITCH AND SHORT TIME CURRENT STANDARD UNITS - VERSION /K

Unit size (all versions)	Main switch type (category AC-23A/B)	Cable section	Bar dimensions	Maximum back-up fuse rating	ICW (0,25s) Short time current rms	Further technical data	
		∅ [mm <sup>2</sup> ]	□ [mm]	[A]	[kA]		
2202	SIRCO 500A	2 x 185	2 x 32 x 6	630	25	<a href="http://socomec.com/files/live/sites/systemsite/files/SCP/pdf_catalogue/GB/cat_Sirco-gb.pdf">http://socomec.com/files/live/sites/systemsite/files/SCP/pdf_catalogue/GB/cat_Sirco-gb.pdf</a>	
2602							
2652							
2702							
2722	SIRCO 800A	min 2 x 185 max 2 x 300	min 2 x 40 x 5 max 2 x 63 x 5	800	27		
3152							
3602							
3902							
4202	SIRCO 1000A	min 2 x 240 max 4 x 185	min 2 x 50 x 5 max 2 x 63 x 5	1000			
4502							
4802							
4812							
4822	SIRCO 1250A CD	4 x 185	min 2 x 60 x 5 max 2 x 63 x 5	1250			
5412							
6002							
6022							
6303	VC5P 1600A 50KA	-	3 x 50 x 8	1600		50	<a href="http://www.technoelectric.it/ing/VCP_tab_dati_ing.html">http://www.technoelectric.it/ing/VCP_tab_dati_ing.html</a>
6903							
7203							
7213							
7223							

### MAXIMUM CABLES/BARS SECTION CONNECTED TO MAIN SWITCH AND SHORT TIME CURRENT STANDARD UNITS - VERSION /A

Unit size (all versions)	Main switch type (category AC-23A/B)	Cable section	Bar dimensions	Maximum back-up fuse rating	ICW (0,25s) Short time current rms	Further technical data	
		∅ [mm <sup>2</sup> ]	□ [mm]	[A]	[kA]		
2202	SIRCO 500A	2 x 185	2 x 32 x 6	630	25	<a href="http://socomec.com/files/live/sites/systemsite/files/SCP/pdf_catalogue/GB/cat_Sirco-gb.pdf">http://socomec.com/files/live/sites/systemsite/files/SCP/pdf_catalogue/GB/cat_Sirco-gb.pdf</a>	
2602							
2652							
2702							
2722	SIRCO 800A	min 2 x 185 max 2 x 300	min 2 x 40 x 5 max 2 x 63 x 5	800	27		
3152							
3602							
3902							
4202	SIRCO 1000A	min 2 x 240 max 4 x 185	min 2 x 50 x 5 max 2 x 63 x 5	1000			
4502							
4802							
4822							
5412	SIRCO 1250A CD	4 x 185	min 2 x 60 x 5 max 2 x 63 x 5	1250			
5703							
6303							
6603							VC5P 1600A 50KA

Electrical data valid for standard units without any additional option  
Voltage tolerance: 10%  
Maximum voltage unbalance: 3%

## 8.1 FULL LOAD SOUND LEVEL

## i-FR-G05-Z/K

SOUND POWER LEVEL IN COOLING									
SIZE	Octave band [Hz]								Total sound level dB(A)
	63	125	250	500	1000	2000	4000	8000	
	Sound power level dB								
2202	100	100	97	96	95	91	83	73	99
2602	101	101	98	97	96	92	84	74	100
2652	101	101	98	97	96	92	84	74	100
2702	101	101	98	97	96	92	84	74	100
2722	102	102	99	98	97	93	85	75	101
3152	102	102	99	98	97	93	85	75	101
3602	102	102	99	98	97	93	85	75	101
3902	103	103	100	99	98	94	86	76	102
4202	104	104	101	100	99	95	87	77	103
4502	104	104	101	100	99	95	87	77	103
4802	105	105	102	101	100	96	88	78	104
4812	105	105	102	101	100	96	88	78	104
4822	106	106	103	102	101	97	89	79	105
5412	106	106	103	102	101	97	89	79	105
6002	106	106	103	102	101	97	89	79	105
6022	106	106	103	102	101	97	89	79	105
6303	106	106	103	102	101	97	89	79	105
6903	106	106	103	102	101	97	89	79	105
7203	106	106	103	102	101	97	89	79	105
7213	107	107	104	103	102	98	90	80	106
7223	107	107	104	103	102	98	90	80	106

### Working conditions

Plant (side) cooling exchanger water (in/out) 12,00°C/7,00°C; Source (side) heat exchanger air (in) 35,0°C.

Sound power on the basis of measurements made in compliance with ISO 9614.

Such certification refers specifically to the sound Power Level in dB(A). This is therefore the only acoustic data to be considered as binding.

Sound power level in cooling, outdoors.

SOUND PRESSURE LEVEL									
SIZE	Octave band [Hz]								Total sound level dB(A)
	63	125	250	500	1000	2000	4000	8000	
	Sound pressure level dB								
2202	68	68	65	64	63	59	51	41	67
2602	69	69	66	65	64	60	52	42	68
2652	69	69	66	65	64	60	52	42	68
2702	69	69	66	65	64	60	52	42	68
2722	70	70	67	66	65	61	53	43	69
3152	69	69	66	65	64	60	52	42	68
3602	69	69	66	65	64	60	52	42	68
3902	70	70	67	66	65	61	53	43	69
4202	71	71	68	67	66	62	54	44	70
4502	71	71	68	67	66	62	54	44	70
4802	72	72	69	68	67	63	55	45	71
4812	72	72	69	68	67	63	55	45	71
4822	73	73	70	69	68	64	56	46	72
5412	73	73	70	69	68	64	56	46	72
6002	73	73	70	69	68	64	56	46	72
6022	73	73	70	69	68	64	56	46	72

### Working conditions

Plant (side) cooling exchanger water (in/out) 12,00°C/7,00°C; Source (side) heat exchanger air (in) 35,0°C.

Average sound pressure level at 10m distance, unit in a free field on a reflective surface; non-binding value calculated from the sound power level.

**FULL LOAD SOUND LEVEL**

**i-FR-G05-Z/K**

<b>SOUND PRESSURE LEVEL</b>									
<b>SIZE</b>	Octave band [Hz]								<b>Total sound level dB(A)</b>
	<b>63</b>	<b>125</b>	<b>250</b>	<b>500</b>	<b>1000</b>	<b>2000</b>	<b>4000</b>	<b>8000</b>	
	Sound pressure level dB								
<b>6303</b>	73	73	70	69	68	64	56	46	<b>72</b>
<b>6903</b>	73	73	70	69	68	64	56	46	<b>72</b>
<b>7203</b>	73	73	70	69	68	64	56	46	<b>72</b>
<b>7213</b>	74	74	71	70	69	65	57	47	<b>73</b>
<b>7223</b>	74	74	71	70	69	65	57	47	<b>73</b>

**Working conditions**

Plant (side) cooling exchanger water (in/out) 12,00°C/7,00°C; Source (side) heat exchanger air (in) 35,0°C.

Average sound pressure level at 10m distance, unit in a free field on a reflective surface; non-binding value calculated from the sound power level.

**FULL LOAD SOUND LEVEL**

**i-FR-G05-Z/SL-K**

<b>SOUND POWER LEVEL IN COOLING</b>									
SIZE	Octave band [Hz]								Total sound level dB(A)
	63	125	250	500	1000	2000	4000	8000	
	Sound power level dB								
2202	93	93	90	89	88	84	76	66	92
2602	94	94	91	90	89	85	77	67	93
2652	94	94	91	90	89	85	77	67	93
2702	94	94	91	90	89	85	77	67	93
2722	95	95	92	91	90	86	78	68	94
3152	95	95	92	91	90	86	78	68	94
3602	95	95	92	91	90	86	78	68	94
3902	96	96	93	92	91	87	79	69	95
4202	97	97	94	93	92	88	80	70	96
4502	97	97	94	93	92	88	80	70	96
4802	97	97	94	93	92	88	80	70	96
4812	97	97	94	93	92	88	80	70	96
4822	97	97	94	93	92	88	80	70	96
5412	97	97	94	93	92	88	80	70	96
6002	97	97	94	93	92	88	80	70	96
6022	97	97	94	93	92	88	80	70	96
6303	97	97	94	93	92	88	80	70	96
6903	97	97	94	93	92	88	80	70	96
7203	97	97	94	93	92	88	80	70	96
7213	98	98	95	94	93	89	81	71	97
7223	98	98	95	94	93	89	81	71	97

**Working conditions**

Plant (side) cooling exchanger water (in/out) 12,00°C/7,00°C; Source (side) heat exchanger air (in) 35,0°C.

Sound power on the basis of measurements made in compliance with ISO 9614.

Such certification refers specifically to the sound Power Level in dB(A). This is therefore the only acoustic data to be considered as binding.

Sound power level in cooling, outdoors.

<b>SOUND PRESSURE LEVEL</b>									
SIZE	Octave band [Hz]								Total sound level dB(A)
	63	125	250	500	1000	2000	4000	8000	
	Sound pressure level dB								
2202	61	61	58	57	56	52	44	34	60
2602	62	62	59	58	57	53	45	35	61
2652	62	62	59	58	57	53	45	35	61
2702	62	62	59	58	57	53	45	35	61
2722	62	62	59	58	57	53	45	35	61
3152	62	62	59	58	57	53	45	35	61
3602	62	62	59	58	57	53	45	35	61
3902	63	63	60	59	58	54	46	36	62
4202	64	64	61	60	59	55	47	37	63
4502	64	64	61	60	59	55	47	37	63
4802	64	64	61	60	59	55	47	37	63
4812	64	64	61	60	59	55	47	37	63
4822	64	64	61	60	59	55	47	37	63
5412	64	64	61	60	59	55	47	37	63
6002	64	64	61	60	59	55	47	37	63
6022	64	64	61	60	59	55	47	37	63

**Working conditions**

Plant (side) cooling exchanger water (in/out) 12,00°C/7,00°C; Source (side) heat exchanger air (in) 35,0°C.

Average sound pressure level at 10m distance, unit in a free field on a reflective surface; non-binding value calculated from the sound power level.

**FULL LOAD SOUND LEVEL**

**i-FR-G05-Z/SL-K**

<b>SOUND PRESSURE LEVEL</b>									
<b>SIZE</b>	Octave band [Hz]								<b>Total sound level dB(A)</b>
	<b>63</b>	<b>125</b>	<b>250</b>	<b>500</b>	<b>1000</b>	<b>2000</b>	<b>4000</b>	<b>8000</b>	
	Sound pressure level dB								
<b>6303</b>	64	64	61	60	59	55	47	37	<b>63</b>
<b>6903</b>	64	64	61	60	59	55	47	37	<b>63</b>
<b>7203</b>	64	64	61	60	59	55	47	37	<b>63</b>
<b>7213</b>	65	65	62	61	60	56	48	38	<b>64</b>
<b>7223</b>	65	65	62	61	60	56	48	38	<b>64</b>

**Working conditions**

Plant (side) cooling exchanger water (in/out) 12,00°C/7,00°C; Source (side) heat exchanger air (in) 35,0°C.

Average sound pressure level at 10m distance, unit in a free field on a reflective surface; non-binding value calculated from the sound power level.



**FULL LOAD SOUND LEVEL**

**i-FR-G05-Z/A**

<b>SOUND POWER LEVEL IN COOLING</b>									
SIZE	Octave band [Hz]								Total sound level dB(A)
	63	125	250	500	1000	2000	4000	8000	
	Sound power level dB								
2202	100	100	97	96	95	91	83	73	99
2602	101	101	98	97	96	92	84	74	100
2652	101	101	98	97	96	92	84	74	100
2702	101	101	98	97	96	92	84	74	100
2722	102	102	99	98	97	93	85	75	101
3152	102	102	99	98	97	93	85	75	101
3602	102	102	99	98	97	93	85	75	101
3902	103	103	100	99	98	94	86	76	102
4202	104	104	101	100	99	95	87	77	103
4502	104	104	101	100	99	95	87	77	103
4802	105	105	102	101	100	96	88	78	104
4822	106	106	103	102	101	97	89	79	105
5412	106	106	103	102	101	97	89	79	105
5703	106	106	103	102	101	97	89	79	105
6303	106	106	103	102	101	97	89	79	105
6603	106	106	103	102	101	97	89	79	105

**Working conditions**

Plant (side) cooling exchanger water (in/out) 12,00°C/7,00°C; Source (side) heat exchanger air (in) 35,0°C.

Sound power on the basis of measurements made in compliance with ISO 9614.

Such certification refers specifically to the sound Power Level in dB(A). This is therefore the only acoustic data to be considered as binding.

Sound power level in cooling, outdoors.

<b>SOUND PRESSURE LEVEL</b>									
SIZE	Octave band [Hz]								Total sound level dB(A)
	63	125	250	500	1000	2000	4000	8000	
	Sound pressure level dB								
2202	68	68	65	64	63	59	51	41	67
2602	69	69	66	65	64	60	52	42	68
2652	68	68	65	64	63	59	51	41	67
2702	68	68	65	64	63	59	51	41	67
2722	69	69	66	65	64	60	52	42	68
3152	69	69	66	65	64	60	52	42	68
3602	69	69	66	65	64	60	52	42	68
3902	70	70	67	66	65	61	53	43	69
4202	71	71	68	67	66	62	54	44	70
4502	71	71	68	67	66	62	54	44	70
4802	72	72	69	68	67	63	55	45	71
4822	73	73	70	69	68	64	56	46	72
5412	73	73	70	69	68	64	56	46	72
5703	73	73	70	69	68	64	56	46	72
6303	73	73	70	69	68	64	56	46	72
6603	73	73	70	69	68	64	56	46	72

**Working conditions**

Plant (side) cooling exchanger water (in/out) 12,00°C/7,00°C; Source (side) heat exchanger air (in) 35,0°C.

Average sound pressure level at 10m distance, unit in a free field on a reflective surface; non-binding value calculated from the sound power level.

**FULL LOAD SOUND LEVEL**

**i-FR-G05-Z/SL-A**

SOUND POWER LEVEL IN COOLING									
SIZE	Octave band [Hz]								Total sound level dB(A)
	63	125	250	500	1000	2000	4000	8000	
	Sound power level dB								
2202	93	93	90	89	88	84	76	66	92
2602	94	94	91	90	89	85	77	67	93
2652	94	94	91	90	89	85	77	67	93
2702	94	94	91	90	89	85	77	67	93
2722	95	95	92	91	90	86	78	68	94
3152	95	95	92	91	90	86	78	68	94
3602	95	95	92	91	90	86	78	68	94
3902	96	96	93	92	91	87	79	69	95
4202	97	97	94	93	92	88	80	70	96
4502	97	97	94	93	92	88	80	70	96
4802	97	97	94	93	92	88	80	70	96
4822	97	97	94	93	92	88	80	70	96
5412	97	97	94	93	92	88	80	70	96
5703	97	97	94	93	92	88	80	70	96
6303	97	97	94	93	92	88	80	70	96

**Working conditions**

Plant (side) cooling exchanger water (in/out) 12,00°C/7,00°C; Source (side) heat exchanger air (in) 35,0°C.

Sound power on the basis of measurements made in compliance with ISO 9614.

Such certification refers specifically to the sound Power Level in dB(A). This is therefore the only acoustic data to be considered as binding.

Sound power level in cooling, outdoors.

SOUND PRESSURE LEVEL									
SIZE	Octave band [Hz]								Total sound level dB(A)
	63	125	250	500	1000	2000	4000	8000	
	Sound pressure level dB								
2202	61	61	58	57	56	52	44	34	60
2602	61	61	58	57	56	52	44	34	60
2652	61	61	58	57	56	52	44	34	60
2702	61	61	58	57	56	52	44	34	60
2722	62	62	59	58	57	53	45	35	61
3152	62	62	59	58	57	53	45	35	61
3602	62	62	59	58	57	53	45	35	61
3902	63	63	60	59	58	54	46	36	62
4202	64	64	61	60	59	55	47	37	63
4502	64	64	61	60	59	55	47	37	63
4802	64	64	61	60	59	55	47	37	63
4822	64	64	61	60	59	55	47	37	63
5412	64	64	61	60	59	55	47	37	63
5703	64	64	61	60	59	55	47	37	63
6303	64	64	61	60	59	55	47	37	63

**Working conditions**

Plant (side) cooling exchanger water (in/out) 12,00°C/7,00°C; Source (side) heat exchanger air (in) 35,0°C.

Average sound pressure level at 10m distance, unit in a free field on a reflective surface; non-binding value calculated from the sound power level.

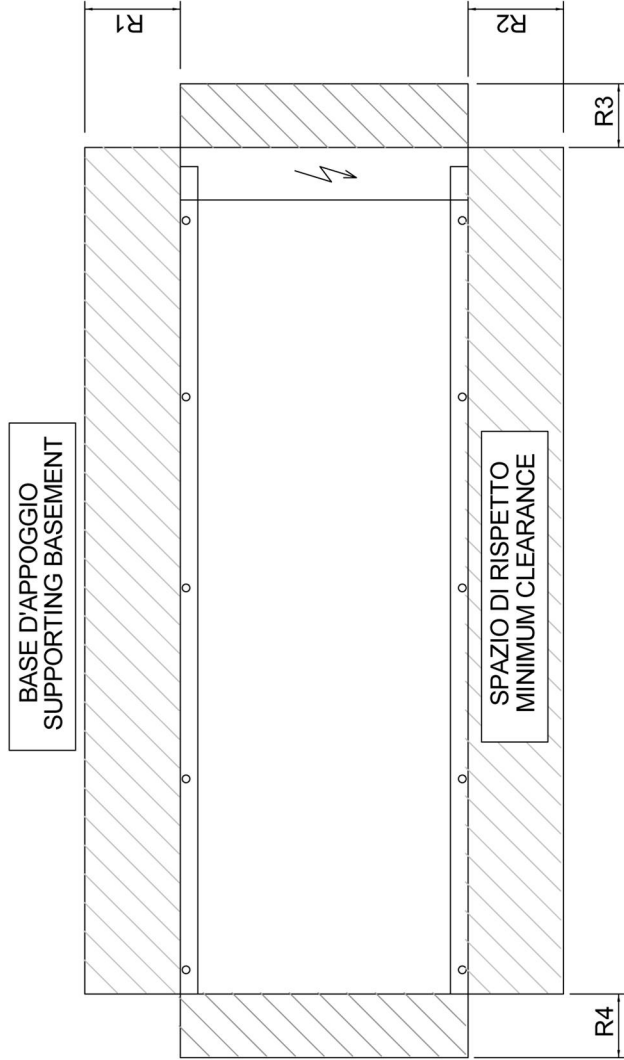
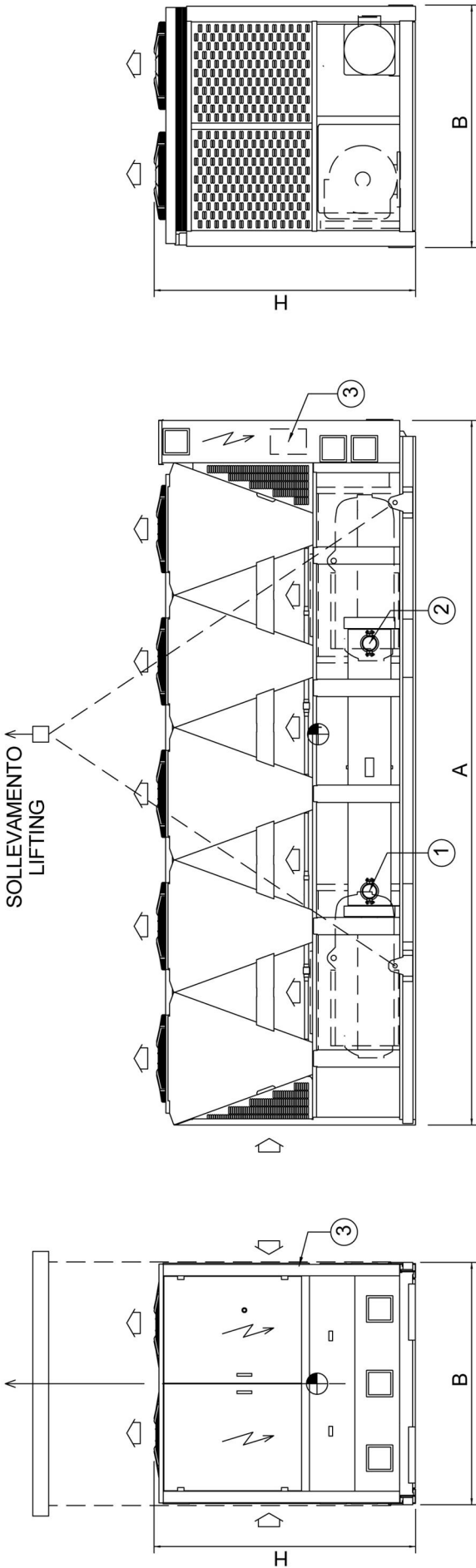

- ENTRATA ARIA  
AIR INLET
- USCITA ARIA  
AIR OUTLET
- BARICENTRO  
CENTER OF GRAVITY
- ① ENTRATA ACQUA EVAPORATORE  
EVAPORATOR WATER INLET
- ② USCITA ACQUA EVAPORATORE  
EVAPORATOR WATER OUTLET
- ③ INGRESSO LINEA ELETTRICA  
POWER INLET

REMARKS: For installation purposes, please refer to the documentation sent after the purchase contract. This technical data should be considered as indicative. Mitsubishi Electric Hydraulics & IT Cooling Systems S.p.A. may modify them at any moment. Data valid for standard units without any additional option.

**DIMENSIONAL DRAWINGS**

**i-FR-G05-Z 2202 - 7223**

[ SI System ]

SIZE	DIMENSIONS AND WEIGHTS				CLEARANCE				HEAT EXCHANGER USER SIDE	
	A	B	H	WEIGHT	R1	R2	R3	R4	IN/OUT	
	[mm]	[mm]	[mm]	[kg]	[mm]	[mm]	[mm]	[mm]	TYPE	Ø
i-FR-G05-Z /K /2202	4150	2260	2500	4790	2000	2300	1500	1500	H	6"
i-FR-G05-Z /K /2602	5400	2260	2500	5270	2000	2300	1500	1500	H	6"
i-FR-G05-Z /K /2652	5400	2260	2500	5280	2000	2300	1500	1500	H	6"
i-FR-G05-Z /K /2702	5400	2260	2500	5330	2000	2300	1500	1500	H	6"
i-FR-G05-Z /K /2722	5400	2260	2500	5720	2000	2300	1500	1500	H	6"
i-FR-G05-Z /K /3152	6650	2260	2500	6210	2000	2300	1500	1500	H	6"
i-FR-G05-Z /K /3602	6650	2260	2500	6270	2000	2300	1500	1500	H	6"
i-FR-G05-Z /K /3902	7900	2260	2500	6700	2000	2300	1500	1500	H	6"
i-FR-G05-Z /K /4202	7900	2260	2500	6740	2000	2300	1500	1500	H	6"
i-FR-G05-Z /K /4502	7900	2260	2500	7350	2000	2300	1500	1500	H	8"
i-FR-G05-Z /K /4802	7900	2260	2500	7750	2000	2300	1500	1500	H	8"
i-FR-G05-Z /K /4812	9150	2260	2500	8220	2000	2300	1500	1500	H	8"
i-FR-G05-Z /K /4822	9150	2260	2500	8340	2000	2300	1500	1500	H	8"
i-FR-G05-Z /K /5412	9150	2260	2500	8500	2000	2300	1500	1500	H	8"
i-FR-G05-Z /K /6002	10400	2260	2500	8890	2000	2300	1500	1500	H	8"
i-FR-G05-Z /K /6022	10400	2260	2500	9000	2000	2300	1500	1500	H	8"
i-FR-G05-Z /K /6303	11650	2260	2500	10650	2000	2300	1500	1500	H	8"
i-FR-G05-Z /K /6903	11650	2260	2500	11460	2000	2300	1500	1500	H	8"
i-FR-G05-Z /K /7203	11650	2260	2500	11840	2000	2300	1500	1500	H	8"
i-FR-G05-Z /K /7213	12900	2260	2500	12350	2000	2300	1500	1500	H	8"
i-FR-G05-Z /K /7223	12900	2260	2500	12430	2000	2300	1500	1500	H	8"
i-FR-G05-Z /SL-K /2202	5400	2260	2500	5450	2000	2300	1500	1500	H	6"
i-FR-G05-Z /SL-K /2602	5400	2260	2500	5600	2000	2300	1500	1500	H	6"
i-FR-G05-Z /SL-K /2652	5400	2260	2500	5620	2000	2300	1500	1500	H	6"
i-FR-G05-Z /SL-K /2702	5400	2260	2500	5650	2000	2300	1500	1500	H	6"
i-FR-G05-Z /SL-K /2722	6650	2260	2500	6560	2000	2300	1500	1500	H	6"
i-FR-G05-Z /SL-K /3152	6650	2260	2500	6580	2000	2300	1500	1500	H	6"
i-FR-G05-Z /SL-K /3602	6650	2260	2500	6590	2000	2300	1500	1500	H	6"
i-FR-G05-Z /SL-K /3902	7900	2260	2500	7050	2000	2300	1500	1500	H	6"
i-FR-G05-Z /SL-K /4202	7900	2260	2500	7100	2000	2300	1500	1500	H	6"
i-FR-G05-Z /SL-K /4502	9150	2260	2500	8110	2000	2300	1500	1500	H	8"
i-FR-G05-Z /SL-K /4802	9150	2260	2500	8550	2000	2300	1500	1500	H	8"
i-FR-G05-Z /SL-K /4812	10400	2260	2500	9010	2000	2300	1500	1500	H	8"
i-FR-G05-Z /SL-K /4822	10400	2260	2500	9130	2000	2300	1500	1500	H	8"
i-FR-G05-Z /SL-K /5412	10400	2260	2500	9310	2000	2300	1500	1500	H	8"
i-FR-G05-Z /SL-K /6002	10400	2260	2500	9270	2000	2300	1500	1500	H	8"
i-FR-G05-Z /SL-K /6022	11650	2260	2500	9790	2000	2300	1500	1500	H	8"
i-FR-G05-Z /SL-K /6303	11650	2260	2500	11140	2000	2300	1500	1500	H	8"
i-FR-G05-Z /SL-K /6903	12900	2260	2500	12390	2000	2300	1500	1500	H	8"
i-FR-G05-Z /SL-K /7203	12900	2260	2500	12770	2000	2300	1500	1500	H	8"
i-FR-G05-Z /SL-K /7213	12900	2260	2500	12850	2000	2300	1500	1500	H	8"
i-FR-G05-Z /SL-K /7223	12900	2260	2500	12930	2000	2300	1500	1500	H	8"
i-FR-G05-Z /A /2202	5400	2260	2500	5180	2000	2300	1500	1500	H	6"
i-FR-G05-Z /A /2602	5400	2260	2500	5240	2000	2300	1500	1500	H	6"
i-FR-G05-Z /A /2652	6650	2260	2500	5720	2000	2300	1500	1500	H	6"
i-FR-G05-Z /A /2702	6650	2260	2500	5800	2000	2300	1500	1500	H	6"
i-FR-G05-Z /A /2722	6650	2260	2500	6210	2000	2300	1500	1500	H	6"
i-FR-G05-Z /A /3152	7900	2260	2500	6620	2000	2300	1500	1500	H	6"
i-FR-G05-Z /A /3602	7900	2260	2500	6670	2000	2300	1500	1500	H	6"
i-FR-G05-Z /A /3902	9150	2260	2500	7080	2000	2300	1500	1500	H	6"
i-FR-G05-Z /A /4202	9150	2260	2500	7120	2000	2300	1500	1500	H	6"
i-FR-G05-Z /A /4502	10400	2260	2500	8110	2000	2300	1500	1500	H	8"

**DIMENSIONAL DRAWINGS**

**i-FR-G05-Z 2202 - 7223**

[ SI System ]

SIZE	DIMENSIONS AND WEIGHTS				CLEARANCE				HEAT EXCHANGER USER SIDE	
	A	B	H	WEIGHT	R1	R2	R3	R4	IN/OUT	
	[mm]	[mm]	[mm]	[kg]	[mm]	[mm]	[mm]	[mm]	TYPE	Ø
i-FR-G05-Z /A /4802	10400	2260	2500	8550	2000	2300	1500	1500	H	8"
i-FR-G05-Z /A /4822	10400	2260	2500	8810	2000	2300	1500	1500	H	8"
i-FR-G05-Z /A /5412	11650	2260	2500	9280	2000	2300	1500	1500	H	8"
i-FR-G05-Z /A /5703	12900	2260	2500	10880	2000	2300	1500	1500	H	8"
i-FR-G05-Z /A /6303	12900	2260	2500	10920	2000	2300	1500	1500	H	8"
i-FR-G05-Z /A /6603	12900	2260	2500	11610	2000	2300	1500	1500	H	8"
i-FR-G05-Z /SL-A /2202	5400	2260	2500	5490	2000	2300	1500	1500	H	6"
i-FR-G05-Z /SL-A /2602	6650	2260	2500	6030	2000	2300	1500	1500	H	6"
i-FR-G05-Z /SL-A /2652	6650	2260	2500	6080	2000	2300	1500	1500	H	6"
i-FR-G05-Z /SL-A /2702	6650	2260	2500	6400	2000	2300	1500	1500	H	6"
i-FR-G05-Z /SL-A /2722	7900	2260	2500	6990	2000	2300	1500	1500	H	6"
i-FR-G05-Z /SL-A /3152	7900	2260	2500	6990	2000	2300	1500	1500	H	6"
i-FR-G05-Z /SL-A /3602	9150	2260	2500	7460	2000	2300	1500	1500	H	6"
i-FR-G05-Z /SL-A /3902	10400	2260	2500	7860	2000	2300	1500	1500	H	6"
i-FR-G05-Z /SL-A /4202	10400	2260	2500	8080	2000	2300	1500	1500	H	6"
i-FR-G05-Z /SL-A /4502	11650	2260	2500	8860	2000	2300	1500	1500	H	8"
i-FR-G05-Z /SL-A /4802	11650	2260	2500	9310	2000	2300	1500	1500	H	8"
i-FR-G05-Z /SL-A /4822	11650	2260	2500	9640	2000	2300	1500	1500	H	8"
i-FR-G05-Z /SL-A /5412	12900	2260	2500	10080	2000	2300	1500	1500	H	8"
i-FR-G05-Z /SL-A /5703	12900	2260	2500	11410	2000	2300	1500	1500	H	8"
i-FR-G05-Z /SL-A /6303	12900	2260	2500	11420	2000	2300	1500	1500	H	8"

## DIMENSIONAL DRAWINGS

### LEGEND OF PIPE CONNECTIONS



**TYPE = H**  
Grooved coupling with weld end counter-pipe user side

NOMINAL PIPE SIZE	PIPE OUTSIDE DIAMETER
ø inches	ø mm
¾	26,7
1	33,7
1 ¼	42,4
1 ½	48,3
2	60,3
2 ½	76,1
3	88,9
3 ½	101,6

NOMINAL PIPE SIZE	PIPE OUTSIDE DIAMETER
ø inches	ø mm
4	114,3
4 ½	127,0
5	139,7
6	168,3
8	219,1
10	273,0
12	323,9
14	355,6

#### UNI ISO 228/13

Pipe threads where pressure-tight joints are not made on the threads - Designation, dimensions and tolerances

##### Used terminology:

G: Pipe threads where pressure-tight joints are not made on the threads

A: Close tolerance class for external pipe threads where pressure-tight joints are not made on the threads

B: Wider tolerance class for external pipe threads where pressure-tight joints are not made on the threads

Internal threads: G letter followed by thread mark (only tolerance class)

External threads: G letter followed by thread mark and by A letter for A class external threads or by B letter for B class external threads.

#### UNI EN 10226-1

Pipe threads where pressure-tight joints are made on the threads - Designation, dimensions and tolerances

##### Used terminology:

Rp: Internal cylindrical threads where pressure-tight joints are made on the threads

Rc: Internal conical threads where pressure-tight joints are made on the threads

R: External conical threads where pressure-tight joints are made on the threads

Internal cylindrical threads: R letter followed by p letter

Internal conical threads: R letter followed by c letter

External conical threads: R letter

DESIGNATION	DESCRIPTION
UNI EN 10226-1 - Rp 1 1/2	Internal cylindrical threads where pressure-tight joints are made on the threads, defined by standard UNI ISO 7/1 Conventional ø 1 1/2"
UNI EN 10226-1 - Rp 2 1/2	Internal cylindrical threads where pressure-tight joints are made on the threads, defined by standard UNI ISO 7/1 Conventional ø 2 1/2"
UNI EN 10226-1 - Rp 3	Internal cylindrical threads where pressure-tight joints are made on the threads, defined by standard UNI ISO 7/1 Conventional ø 3"
UNI EN 10226-1 - R 3	External conical threads where pressure-tight joints are made on the threads, defined by standard UNI ISO 7/1 Conventional ø 3"
UNI ISO 228/1 - G 4 B	Internal cylindrical threads where pressure-tight joints are not made on the threads, defined by standard UNI ISO 228/1 Tolerance class B for external thread Conventional ø 4"
DN 80 PN 16	Flange Nominal Diameter: 80 mm Nominal Pressure: 16 bar

#### NOTE:

Conventional diameter value [in inches] identifies short thread designation, based upon the relative standard.

All relative values are defined by standards.

As example, here below some values:

	UNI EN 10226-1	UNI ISO 228/1
Conventional ø	1"	1"
Pitch	2.309 mm	2.309 mm
External ø	33.249 mm	33.249 mm
Core ø	30.291 mm	30.291 mm
Thread height	1.479 mm	1.479 mm

## VARIABLE FLOW CONTROL

Pump energy consumption significantly impacts plant running costs, but it can be considerably reduced thanks to the use of variable speed pumps (inverter driven pumps), capable of adjusting the water flow rate according to the actual plant thermal load.

Mitsubishi Electric Hydronics & Cooling Systems has developed the VPF control series (Variable Primary Flow), that provides different water flow regulation logics specifically devoted to various hydraulic

plant solutions: only a primary circuit, primary and secondary circuits, single unit or multi-unit systems.

The VPF systems adjust the pump speeds on the basis of the plant's thermal load and optimize the unit's thermoregulation algorithm for variable flow operation, in a dynamic and simultaneous way. This ensures the highest energy savings, stable operation, and complete reliability.

### VPF.E SYSTEM (delta T control) For plants with primary circuit.

#### VPF.E - Plant and unit requirements

The VPF.E logic provides the variable flow control for the plant's primary circuit.

- Type of plant: Primary circuit only, that feeds hydronic terminals fitted with bypass.
- Hydronic module: Modulating regulation devices (0-10V signal) (provided as standard on these units) or variable speed pumps.
- Unit thermoregulation: Control of the leaving water temperature.
- Monitored parameter: Delta T on primary circuit.

Plant diagram

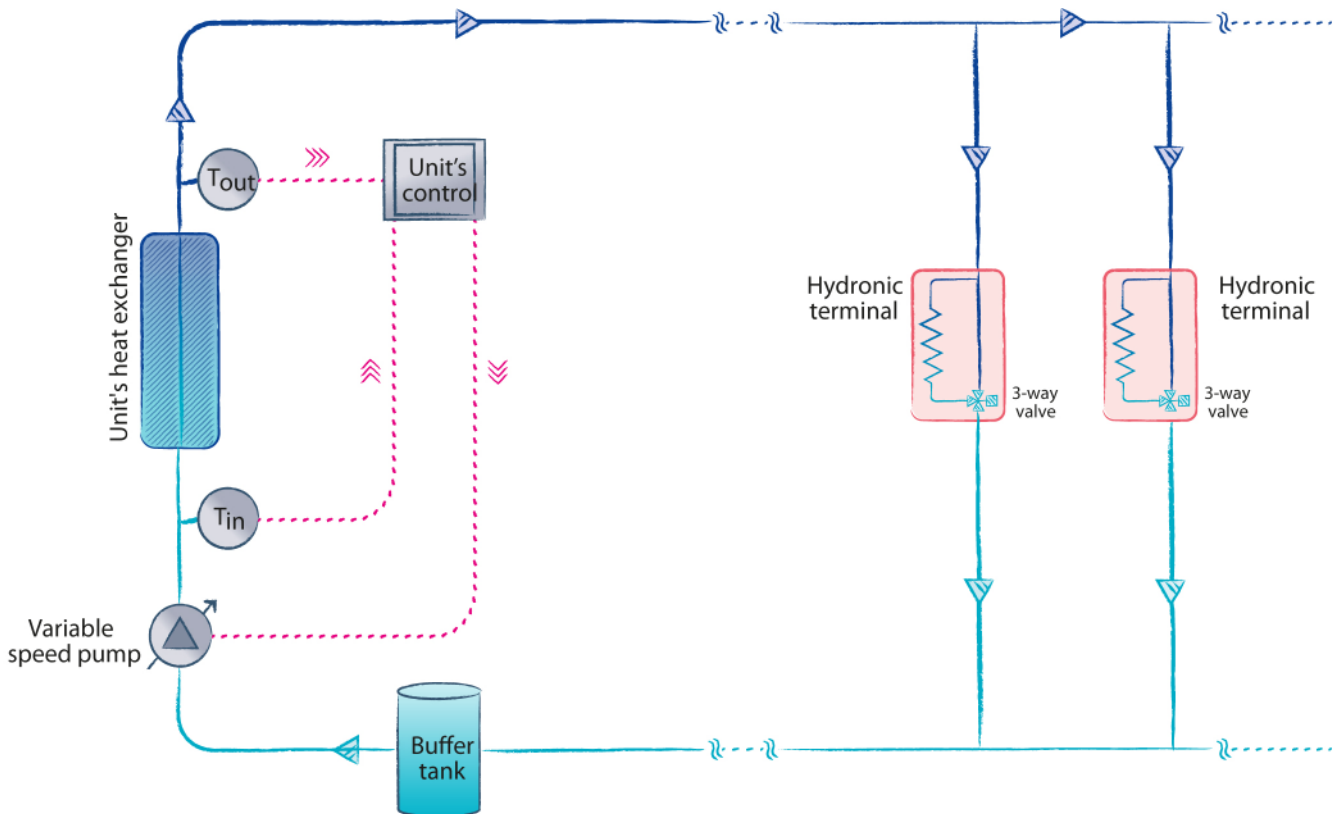

#### VPF.E - Operating logic

##### Water flow regulation

The VPF.E system monitors the temperature difference of the primary circuit ( $\Delta T$ ) and adjusts the primary circuit's pump speed in order to keep it within a defined range ( $\Delta T_{min} \leftrightarrow \Delta T_{max}$ ).

- If  $\Delta T_{min} \leq \Delta T \leq \Delta T_{max}$   
The plant water flow is appropriate to the thermal load, the pump speed is kept constant.
- If  $\Delta T < \Delta T_{min}$   
The plant water flow exceeds what is necessary to properly cover the thermal load, the pump speed is reduced to save pump energy.
- If  $\Delta T > \Delta T_{max}$   
The plant water flow is too low to ensure the proper feed to the users, the pump speed is increased.

With the VPF.E system, the water flow can be reduced to 50% of the unit nominal water flow, with regards to the selection conditions, provided that the minimum water flow required by the unit's heat exchanger is respected (the control of the heat exchanger's minimum water flow is described below).

The pump speed regulation is performed with little progressive adjustments while continuously monitoring the value of the temperature difference on the primary circuit.

The absence of abrupt water flow changes prevents fluctuation due to possible conflicts with the unit's thermoregulation function (compressor regulation).

##### Control of the unit's minimum water flow

Under no circumstances can the primary circuit water flow be reduced below the minimum water flow required by the unit's heat exchanger. The unit's minimum water flow is ensured by setting the minimum pump speed (service menu parameter).



**VPF SYSTEM (delta P control)**  
**For plants with only a primary circuit**

**VPF - Plant and unit requirements**

The VPF logic provides the variable flow control for the plant's primary circuit.

- Type of plant: Primary circuit only, that feeds hydronic terminals fitted with a 2-way regulating valve.
- Hydronic module: Modulating regulation devices (0-10V signal) or variable speed pumps.
- Unit thermoregulation: Control of the leaving water temperature.
- Monitored parameter: Delta P on relevant users' hydronic terminal.

Plant diagram for single unit system

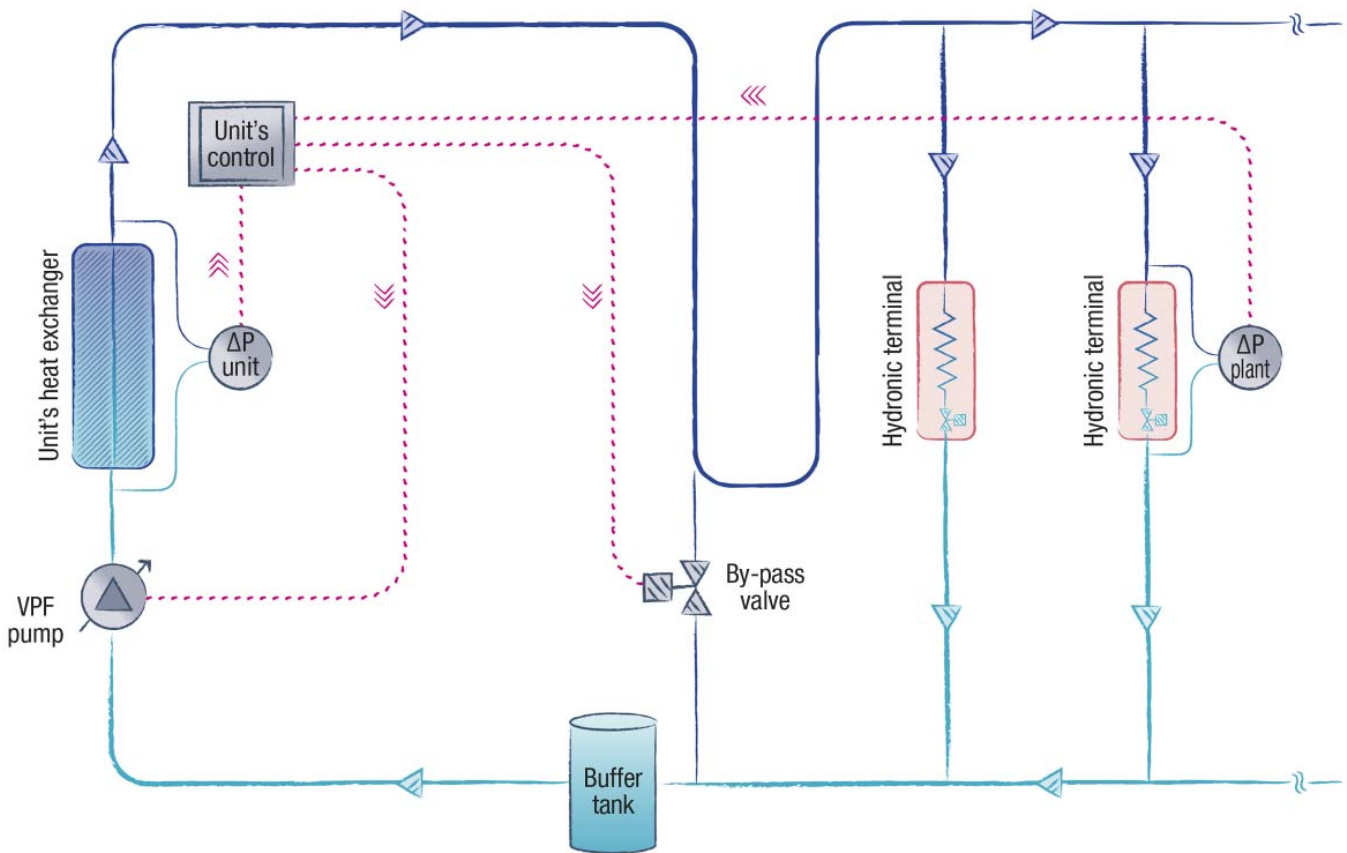



## Plant diagram for multi-unit system

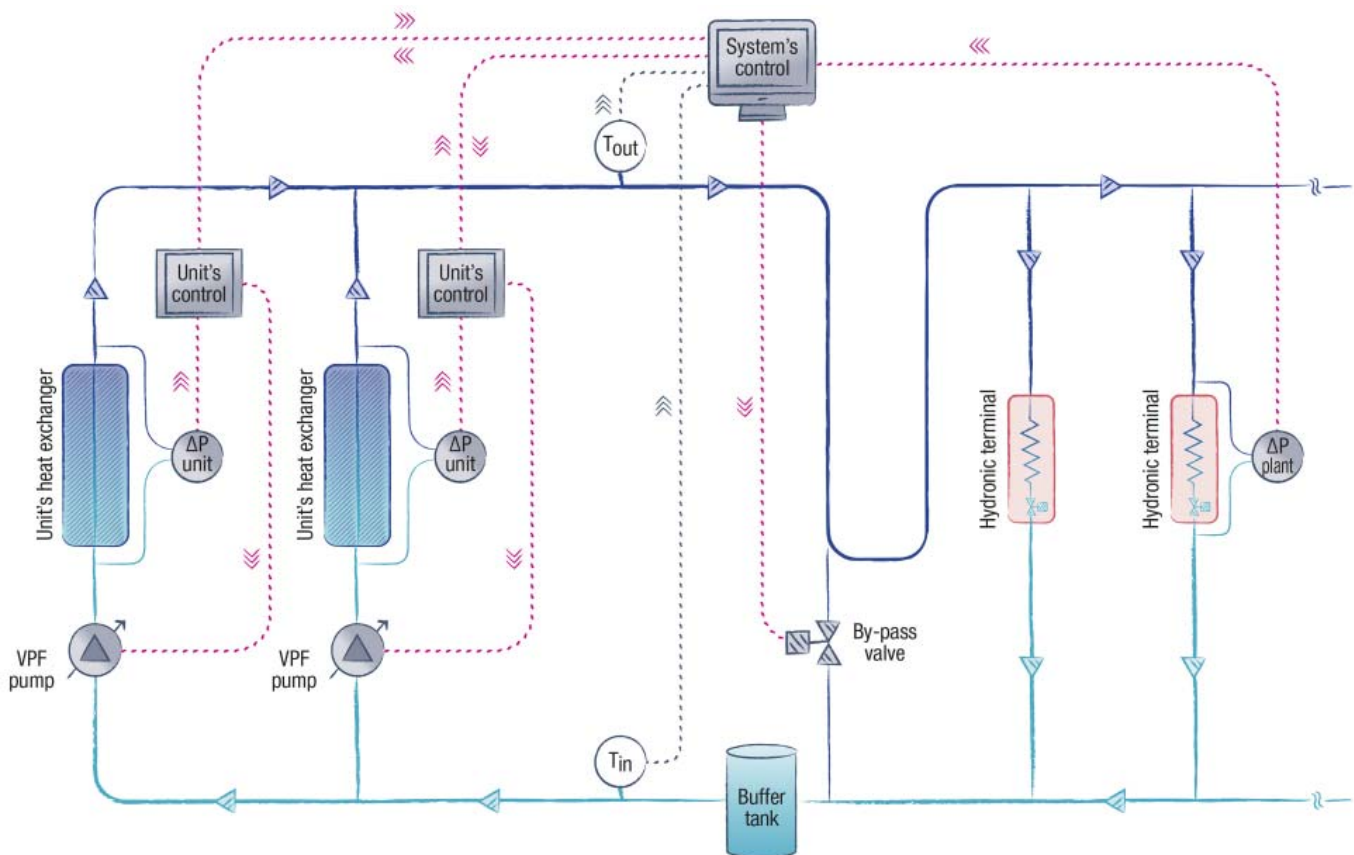

### VPF - Operating logic

#### Water flow regulation

The VPF system monitors the differential pressure on the plant side ( $\Delta P$ ) and adjusts the pump speed in order to keep it within a defined range ( $\Delta P_{min} \leftrightarrow \Delta P_{max}$ ).

- If  $\Delta P_{min} \leq \Delta P \leq \Delta P_{max}$   
The plant water flow is appropriate to the thermal load, the pump speed is kept constant.
- If  $\Delta P > \Delta P_{max}$   
The plant water flow exceeds what is necessary to properly cover the thermal load, the pump speed is reduced to save pump energy.
- If  $\Delta P < \Delta P_{min}$   
The plant water flow is too low to ensure the proper feed to the hydronic terminals, the pump speed is increased.

With the VPF system, the water flow can be reduced to 50% of the unit nominal water flow, with regards to the selection conditions, provided that the minimum water flow required by the unit's heat exchanger is respected (the control of the heat exchanger's minimum water flow is described below).

The pump speed regulation is performed with little progressive adjustments while continuously monitoring the values of both the delta P on the plant side and the water temperature on the heat exchanger. The absence of abrupt water flow changes prevents fluctuation due to possible conflicts with the unit's thermoregulation function (compressor regulation).

#### Control of the unit's minimum water flow

Under no circumstances can the primary circuit water flow be reduced below the minimum water flow required by the unit's heat exchanger. The monitoring of the unit's water flow is performed through a factory installed differential pressure transducer on the unit's heat exchanger. If the differential pressure on the plant side requests a user's water flow lower than the unit's minimum water flow, the VPF system commands the gradual opening of the hydraulic by-pass valve (safety function). This ensures that the minimum water flow required by the unit's heat exchanger is always provided. As soon as the hydronic terminals request an increase of the water flow ( $\Delta P < \Delta P_{min}$ ), the VPF closes the by-pass valve.

#### Multi-unit systems

The VPF control logic is also the same for multi-unit systems. The plant side differential pressure transducer reading and the by-pass valve opening are managed by the multi-unit control system (Manager3000 or ClimaPRO). Each unit autonomously adjusts its pump speed on the basis of the information provided by the multi-unit control system. When the plant load requests the activation of a stand-by unit, the multi-unit control system calculates the starting speed of its pump in order to avoid excessive water flow variation of the running units.

## VPF - Devices and installation

Device	Accessory name		
	VPF (plant DP trans excl)	VPF (plant DP trans incl)	VPF MULTI-UNIT SYSTEM
Differential pressure transducer on the unit's heat exchanger and related controller expansion board	Factory installed	Factory installed	Factory installed
Controller expansion board to read the plant side differential pressure transducer (4-20mA signal) and manage the hydraulic by-pass valve opening (0-10V signal)	Factory installed	Factory installed	Factory installed on the multi-unit control system <sup>(2)</sup>
Plant side differential pressure transducer	Not included (the supply is the customer's responsibility) <sup>(1)</sup>	Factory supplied, installation is the client's responsibility <sup>(1)(2)</sup>	Factory supplied with the multi-unit control system, installation is the client's responsibility <sup>(1)(3)</sup>
Plant side hydraulic by-pass valve	Not included (the supply is the customer's responsibility) <sup>(4)</sup>	Not included (the supply is the customer's responsibility) <sup>(4)</sup>	Not included (the supply is the customer's responsibility) <sup>(4)</sup>

- (1) It is recommended to install the differential pressure transducer on the most hydraulically critical hydronic terminal, to ensure it has a proper water flow in any load condition.
- (2) Technical features of the differential pressure transducer supplied:  
 Model: Huba Control 692.9 120071C1  
 Pressure range: 0 ... + 1 bar  
 Output: 4-20mA  
 Electrical connection: DIN EN 175301-803-A (IP 65)  
 Pressure connection adapters: male threaded G 1/8"
- (3) It is the customer's responsibility to configure the multi-unit control system (Manager3000 or ClimaPRO) with option VPF.
- (4) See attached table for information on the hydraulic by-pass design.

The following table provides the indications for a correct hydraulic by-pass design.

Heat exchanger minimum flow (m <sup>3</sup> /h) <sup>(1)</sup>	Minimum by-pass diameter	Minimum by-pass valve diameter	Suggested valve model	Kvs	Suggested actuator model
From 19 to 30	DN50 (2")	DN50 (2")	VVG41.50	40	SKB60
Up to 37	DN65 (2" ½)	DN65 (2" ½)	VVF31.65	49	SKB60
Up to 60	DN80 (3")	DN80 (3")	VVF31.80	78	SKB60
Up to 95	DN100 (4")	DN100 (4")	VVF31.90	124	SKC60
Up to 150	DN125 (5")	DN125 (5")	VVF31.91	200	SKC60
Up to 230	DN150 (6")	DN150 (6")	VVF31.92	300	SKC60

- (1) In case of a multi-unit system, the unit with the highest minimum water flow should be the reference.

## VPF.D SYSTEM (delta T control)

For plants with primary and secondary circuits separated by a hydraulic decoupler.

### VPF.D - Plant and unit requirements

The VPF.D logic provides the variable flow control for the plant's primary circuit.

- Type of plant: Primary and secondary circuits separated by a hydraulic decoupler.
- Hydronic module: Modulating regulation devices (0-10V signal) or variable speed pumps.
- Unit thermoregulation: Control of the leaving water temperature.
- Monitored parameter: Delta T on primary circuit.

Plant diagram for single unit system

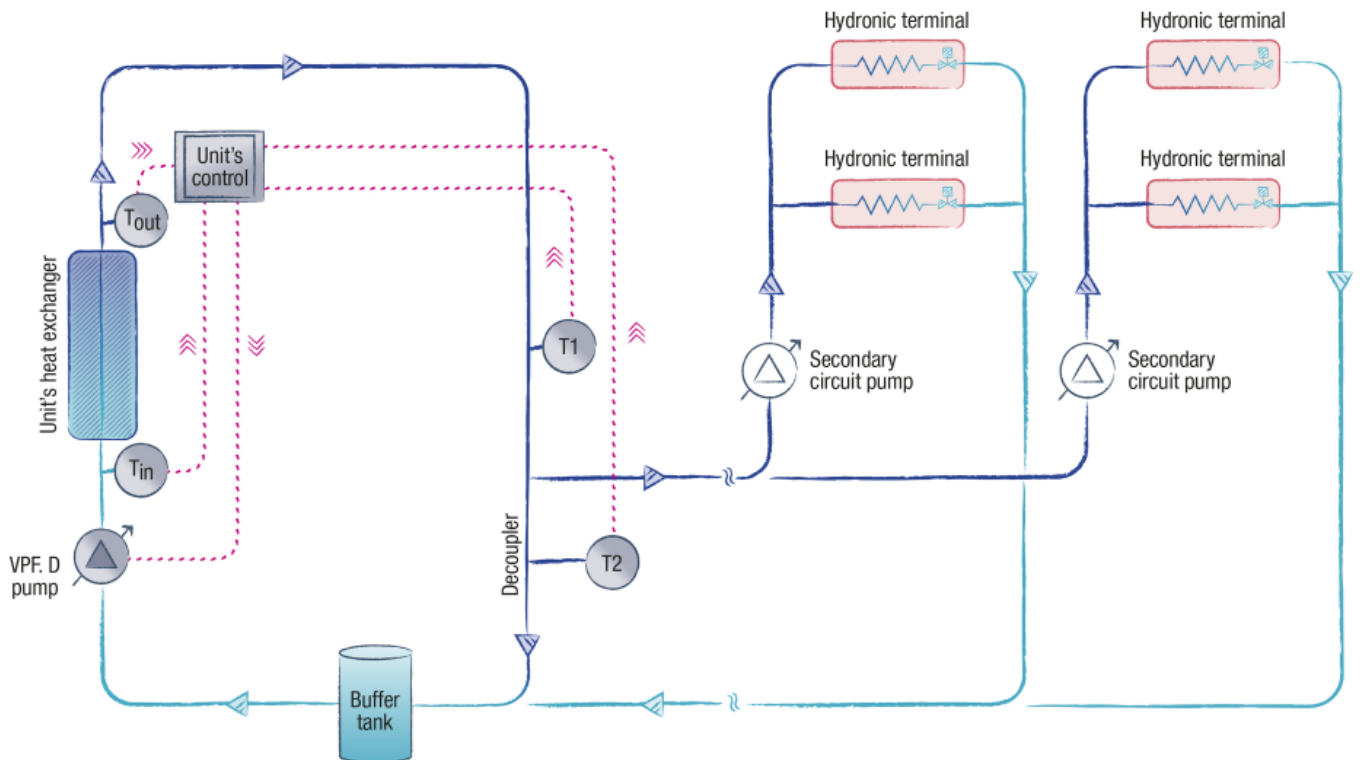

Plant diagram for multi-unit system

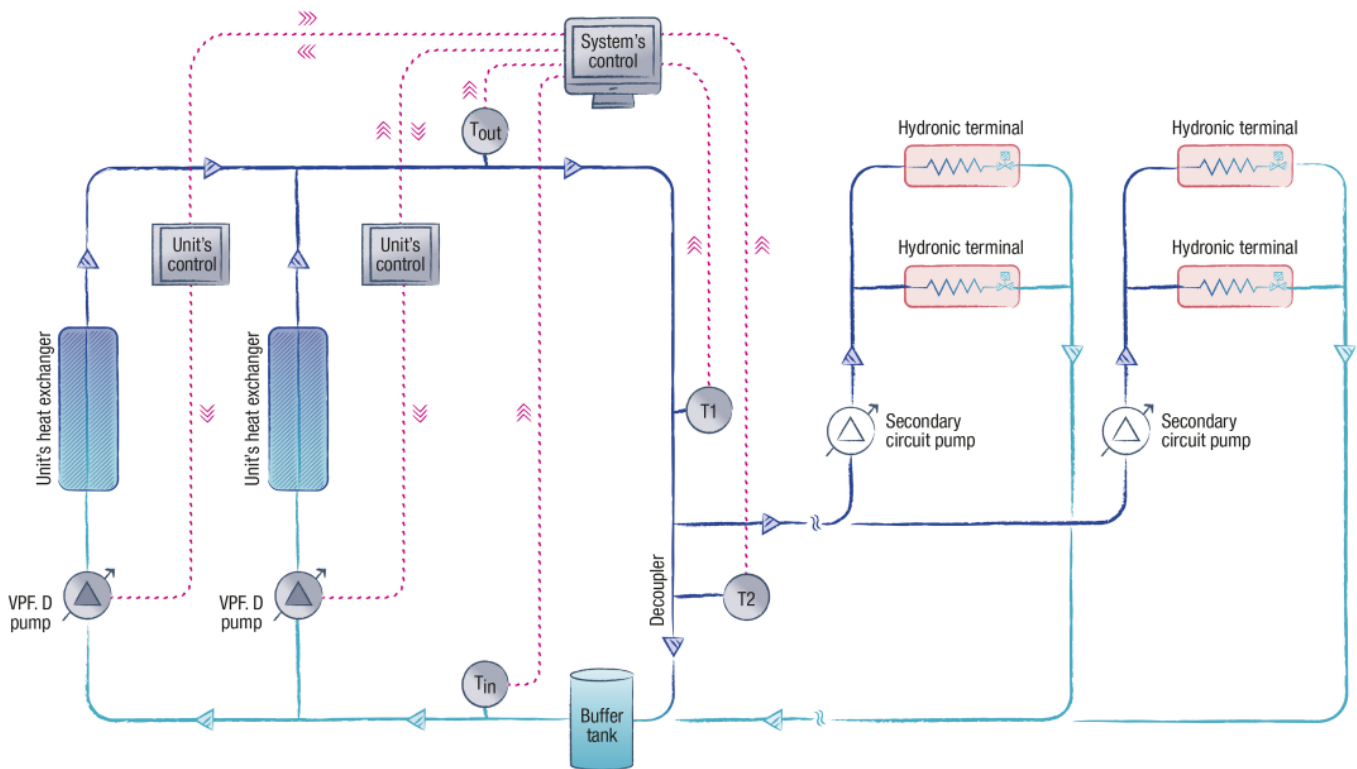

## VPF.D - Operating logic

### Water flow regulation

The VPF.D system monitors the temperature difference of the primary circuit ( $\Delta T$ ) (that corresponds to the temperature difference of the unit's heat exchanger in the case of a single unit system), and adjusts the primary circuit's pump speed in order to keep it within a defined range ( $\Delta T_{min} \leftrightarrow \Delta T_{max}$ ). The secondary circuit water flow is completely independent and is to be managed by the client.

- If  $\Delta T_{min} \leq \Delta T \leq \Delta T_{max}$   
The plant water flow is appropriate to the thermal load, the pump speed is kept constant.
- If  $\Delta T < \Delta T_{min}$   
The plant water flow exceeds what is necessary to properly cover the thermal load, the pump speed is reduced to save pump energy.
- If  $\Delta T > \Delta T_{max}$   
The plant water flow is too low to ensure the proper feed to the users, the pump speed is increased.

To prevent the returning water of the secondary circuit from recirculating through the decoupler and mixing with the delivery water, which would cause serious plant regulation problems, the VPF.D provides a safety function based on the temperatures, which are detected by two probes on the plant side: T1 on the unit delivery line and T2 on the hydraulic decoupler. If during the water flow regulation of the circuits, the flow direction in the decoupler reverses (detected temperatures  $T1 < T2$ ), the system forces a quick increase of the primary water flow until the correct direction of the flow in the decoupler is restored (detected temperatures  $T1 = T2$ ).

With the VPF.D system, the water flow can be reduced to 50% of the unit nominal water flow, with regards to the selection conditions, provided that the minimum water flow required by the unit's heat exchanger is respected (the control of the heat exchanger's minimum water flow is described below).

The pump speed regulation is performed with little progressive adjustments while continuously monitoring the values of both the temperature difference on the primary circuit and the temperatures of the probes T1 and T2. The absence of abrupt water flow changes prevents fluctuation due to possible conflicts with the unit's thermoregulation function (compressor regulation).

### Control of the unit's minimum water flow

Under no circumstances can the primary circuit water flow be reduced below the minimum water flow required by the unit's heat exchanger. The unit's minimum water flow is ensured by setting the minimum pump speed (service menu parameter).

### Multi-unit systems

The VPF.D control logic is also the same for multi-unit systems. The reading of the temperature difference on the primary circuit and the reading of the temperature probes T1 and T2 is managed by the multi-unit control system (Manager3000 or ClimaPRO). Each unit autonomously adjusts its pump speed on the basis of the information provided by the multi-unit control system. When the plant load requests the activation of a stand-by unit, the multi-unit control system calculates the starting speed of its pump in order to avoid excessive water flow variation of the running units.

## VPF.D - Devices and installation

Device	Accessory name	
	VPF.D	VPF.D MULTI-UNIT SYSTEM
2 plant side NTC temperature sensors and related controller expansion board	Factory supplied (probes supplied without wells), installation is the client's responsibility <sup>(1)</sup>	Factory supplied with the multi-unit control system (probes supplied without wells), installation is the client's responsibility <sup>(1)(2)</sup>

(1) It is recommended to install the temperature probes as shown in the enclosed plant diagrams (T1 on the unit delivery line, T2 on the hydraulic decoupler)

(2) It is the customer's responsibility to configure the multi-unit control system (Manager3000 or ClimaPRO) with option VPF.D.

The following table provides the indications for a correct hydraulic decoupler design.

Heat exchanger minimum flow (m <sup>3</sup> /h) <sup>(1)</sup>	Minimum hydraulic decoupler diameter
From 25 to 40	DN65 (2" ½)
Up to 60	DN80 (3")
Up to 100	DN100 (4")
Up to 150	DN125 (5")
Up to 225	DN150 (6")
Up to 375	DN200 (8")

(2) In case of a multi-unit system, the unit with the highest minimum water flow should be the reference.



for a greener tomorrow

Eco Changes is the Mitsubishi Electric Group's environmental statement, and expresses the Group's stance on environmental management. Through a wide range of businesses, we are helping contribute to the realization of a sustainable society.



## **MITSUBISHI ELECTRIC HYDRONICS & IT COOLING SYSTEMS S.p.A.**

Head Office: Via Roma 5 • 27010 Valle Salimbene (PV) • Italy  
Ph. (+39) (0) 382 433 811 • Fax (+39) (0) 382 587148

[www.rcitcooling.com](http://www.rcitcooling.com)  
[www.melcohit.com](http://www.melcohit.com)